



CaviBlaster 2570-D

Operation & Maintenance Manual





CAVIDYNE, LLC IS NOT RESPONSIBLE FOR DAMAGES OR INJURY RESULTING FROM FAILURE TO COMPLY WITH INSTRUCTIONS IN THIS MANUAL. PLEASE READ THE ENTIRE MANUAL CAREFULLY BEFORE USE.



THE CAVIBLASTER 2570-D MUST ONLY BE OPERATED AND MAINTAINED BY TRAINED PERSONNEL.



THIS EQUIPMENT GENERATES HIGH PRESSURE WATER AND IS INTENDED FOR UNDERWATER USE ONLY. SERIOUS PERSONAL INJURY OR DEATH MAY RESULT FROM IMPROPER USE.



COMMERCIAL DIVER'S GEAR SHOULD BE USED TO OPERATE THE CAVIBLASTER SYSTEM.



DO NOT USE AIR PRESSURE HIGHER THAN 120-PSI (8 BAR) WHEN STARTING THE EQUIPMENT. SERIOUS DAMAGE TO THE EQUIPMENT WILL OCCUR.

Unit Specifications:

The CaviBlaster 2570-D power unit consists of a 145HP (108 kW) JCB diesel power- pack and a Giant GP8135 triplex plunger pump. Detailed performance and specifications are listed below:

CaviBlaster 2570-D Specifications	
Nominal Pump Flow	25 gpm (95 LPM)
Nozzle Operating Pressure	7,250-PSI (500 BAR)
Engine	145 HP (108 KW), Diesel Powered (JCB DIESEL)
Installation Environment	Outdoor enclosed or exposed <i>See Section 4 for installation requirements</i>
Fuel Requirements	Diesel fuel (ASTM Grade No. 1-D or 2-D, or EN 590)
Fuel Tank Capacity	50 Gallons (190 Liters)
Water Inlet Pressure Limits	75-PSI Minimum to 100-PSI Maximum (5.2 BAR to 6.9 BAR) <i>See Section 4 for further requirements</i>
Overall Unit Dimensions (L x W x H)	97" x 57" x 63" (247 cm x 145 cm x 160 cm)
Maximum Pressure Hose Length	600 LF (200 meters) of 3/4" (19mm) diameter
Power Unit Weight (Dry)	5,000 LBS (2270 KG)
Zero-Thrust Gun Weight	11 LBS (5 KG)

Figure 1.1 – Specifications

General Description:

The CaviBlaster 2570-D high-pressure waterpower unit allows the operator to use the water flow and pressure to generate cavitation at the end of the proprietary nozzle.

The CaviBlaster cleans the surface of any underwater structure and crushes concrete using the energy released by the implosion of the bubbles during the cavitation process. When directed at the surface being cleaned, the energy released by the collapsing bubbles causes marine growth to be removed from the surface.

The system consists of a portable, zero-thrust gun/guns, connecting high-pressure hose and a diesel-powered, high-pressure pumping unit. The zero-thrust gun/guns uses a trigger-operated valve to control the water stream on and off. If the valve is closed, the power unit goes into bypass mode unloading the engine and the pump.



FULL LOAD IS DEFINED AS THE ENGINE AT FULL THROTTLE / FULL SPEED. IF PARTIALLY THROTTLED, THE ENGINE WILL STALL, CREATING AN UNDESIRABLE RUNNING CONDITION FOR THE BELT DRIVE SYSTEM.

The CaviBlaster 2570-D Power Unit is a complete “plug and play” system built into a self-supporting frame that allows quick deployment and/or installation of the unit. Water can be supplied from either a pressurized source, directly from the natural source via a belt-driven booster pump supplied with the power unit, or from a gravity feed storage tank.

The unit is equipped with many features to maintain operator safety while operating at pressures of 7,250-PSI (500 BAR).

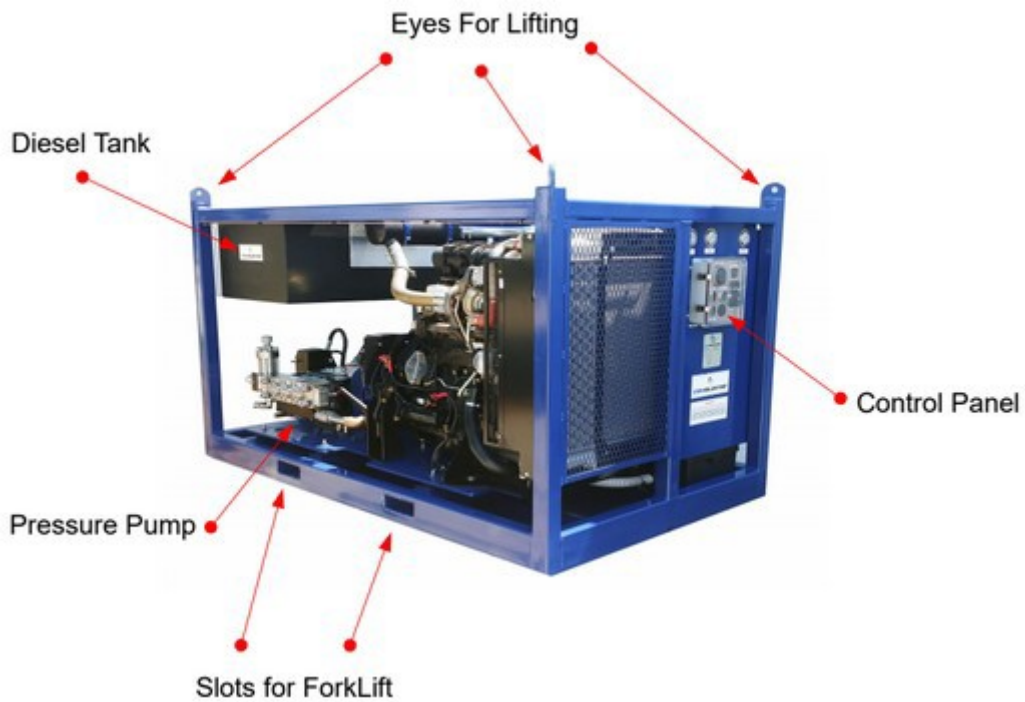

Figure 2.1 – General Features

NOTE: New generation Diesel engines with emission control requirements at a level “Tier 4F” in USA and “Stage V” in EU governed by computer systems with better electric control and higher redundancy of safety features **DO NOT** require an Emergency Stop Button.

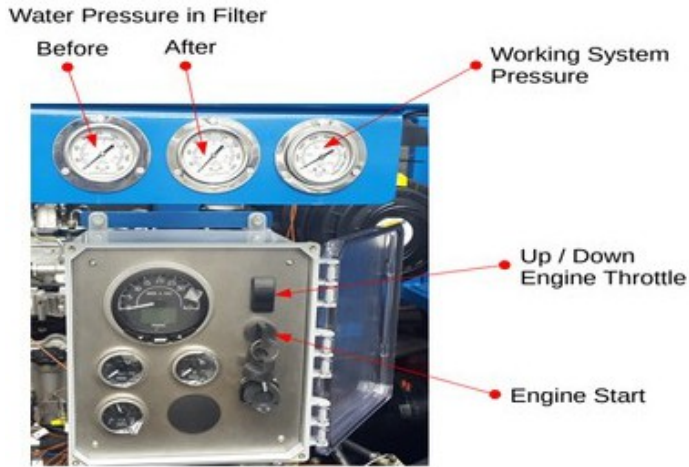

Figure 2.2 – Control Panel

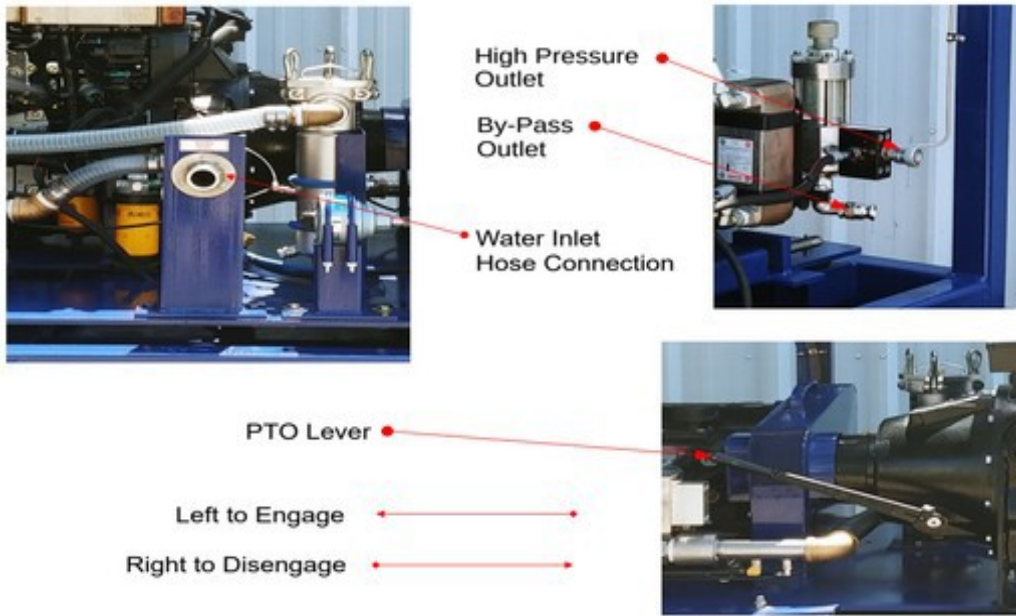

Figure 2.3 – PTO Lever & Hose Connections

Using this Manual:

Every attempt has been made to ensure that this documentation is complete and accurate at the time of publication. It is imperative; however, that anyone attempting to use this manual must have good comprehension of how this equipment operates. Further, this manual can in no way replace the common sense of an individual. If at any time this manual seems to contradict itself, or common sense, discontinue the procedure, re-read the section, and seek assistance from CaviDyne or other personnel familiar with the operation of this equipment.

Safety Information:

The CaviBlaster 2570-D Power Unit is an inherently powerful and potentially dangerous piece of equipment; however, with proper care and training it can be operated safely. The 2570 must only be operated by personnel that have read and understand this manual. It is intended to reinforce and review safety techniques to prevent personal injuries and property damage.

Users must comply with all local, state, and national laws concerning high-pressure water jetting equipment as well as all underwater work regulations.

It is strongly recommended that this entire manual be reviewed in-depth before operating or servicing this equipment. Service work should only be performed by individuals who are proficient in using and maintaining this equipment. Refer to the applicable section in this manual for the correct procedures prior to any installation, setup, or maintenance work.

Personal Safety:

Operation of the CaviBlaster 2570-D underwater cleaning system must only be attempted by commercial divers or other personnel who have been trained in its use. Appropriate protective equipment should always be worn. Operation of the system without the proper equipment and training can result in personal injury.



CAVIDYNE, LLC IS NOT RESPONSIBLE FOR DAMAGES OR INJURIES RESULTING FROM A FAILURE TO COMPLY WITH INSTRUCTIONS IN THIS MANUAL. PLEASE READ AND STUDY THE ENTIRE MANUAL CAREFULLY BEFORE USE.



IF INSPECTION OR CALIBRATION OF THE CAVIBLASTER LANCE IS BEING CONDUCTED OUT OF THE WATER, REMEMBER THAT THE ZERO- THRUST LANCE HAS FRONT AND REAR JETS. NEVER DIRECT THE JET STREAMS AT A PERSON OR ANIMAL. NEVER DIRECT THE JET STREAMS TOWARD POWER LINES OR OTHER HIGH VOLTAGE EQUIPMENT.



ENSURE THAT THERE IS A SAFE AREA TO WORK WHILE OPERATING THE CAVIBLASTER 2570-D.



SEEK IMMEDIATE MEDICAL ATTENTION IF THE OPERATOR SUFFERS AN INJURY AS THE RESULT OF CONTACT WITH THE HIGH-PRESSURE WATER STREAM. SERIOUS PERSONAL INJURY CAN RESULT FROM AN UNTREATED WATER INJECTION WOUND.

Personal Protective Equipment:

Always wear appropriate Personal Protective Equipment (PPE) when operating this equipment.

Personnel operating or working in the vicinity of the power unit should wear appropriate hearing protection when the CaviBlaster system is in use. If the diver is not wearing a diving helmet, hearing protection is recommended. CaviDyne recommends wearing vented earplugs such as “Doc’s Proplugs” for diver hearing protection.

The operators of the CaviBlaster system should always wear neoprene or heavy rubber gloves to provide protection to the hands and nails. The gloves will absorb most of the energy produced by bursting cavitation bubbles and prevent the cavitation bubbles from contacting the operators’ hands. The gloves will also protect operators’ hands from the initial shockwave when the lance is activated.



FAILURE TO WEAR APPROPRIATE PPE MAY RESULT IN PERSONAL INJURY.

Modification to the Equipment:

Do not make any unauthorized modifications or repairs to this equipment. Components used throughout this assembly were specifically designed or selected to safely meet the unique high-pressure requirements. Only replace parts with those recommended by or supplied by CaviDyne. Any unapproved modifications will void the equipment warranty. Unauthorized modification or part substitution can result in serious personal injury or property damage.



UNAUTHORIZED REPLACEMENT OF ANY PART MAY LEAD TO CATASTROPHIC EQUIPMENT FAILURE AND SERIOUS PERSONAL INJURY.

Installation:

The CaviBlaster 2570-D must be installed in accordance with the requirements outlined below. The unit can be installed in a vehicle to allow for maximum mobility and flexibility.

Uncrating and Lifting:

Unpack the equipment and inspect for damage. If damage is found, immediately contact CaviDyne and the shipping company. If the unit will not be installed immediately, provide adequate indoor storage to protect against damage.

The CaviBlaster power unit should be lifted from underneath the frame using the forklift channels or by using the lifting eyes provided on top of the frame. Verify that lifting equipment is rated for the weight listed in **Section 1.0 UNIT SPECIFICATIONS** and that the unit is stable before lifting.

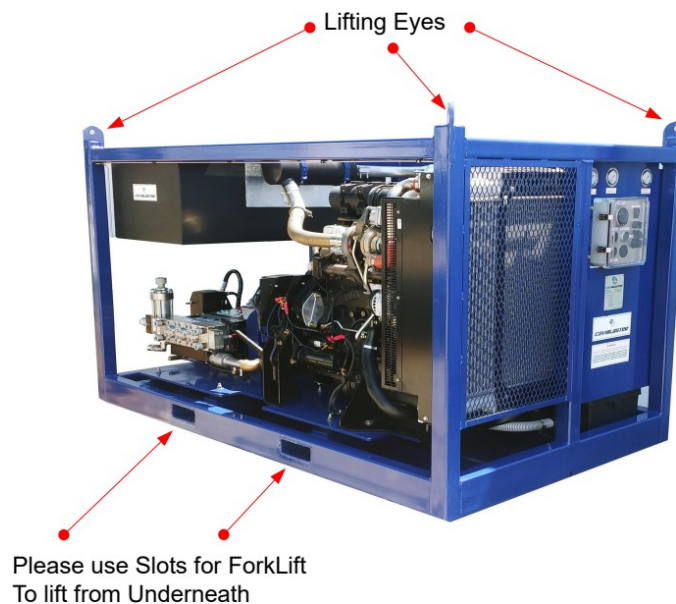

Figure 4.1 – Lifting Guidelines

Installation Location:

For maximum flexibility the CaviBlaster power unit should be installed in an area where it can reach both its water source and anticipated cleaning targets within acceptable hose lengths. The CaviBlaster power unit can be installed in an enclosed* or open environment.

* Enclosed installations will require provisions for adequate engine cooling air flow and for venting of engine exhaust. See **Figure 4.2** below.

Installation location must be a level surface able to safely support the unit weight listed in **Section 1.0 UNIT SPECIFICATIONS**. Orient unit to allow unrestricted access to the hose connection plate and control panel, located on the front of the unit. Allow a minimum of three feet behind the unit and access from above to conduct service and repair work. Take note of frequently serviced areas such as the engine, belts and fuel tank.

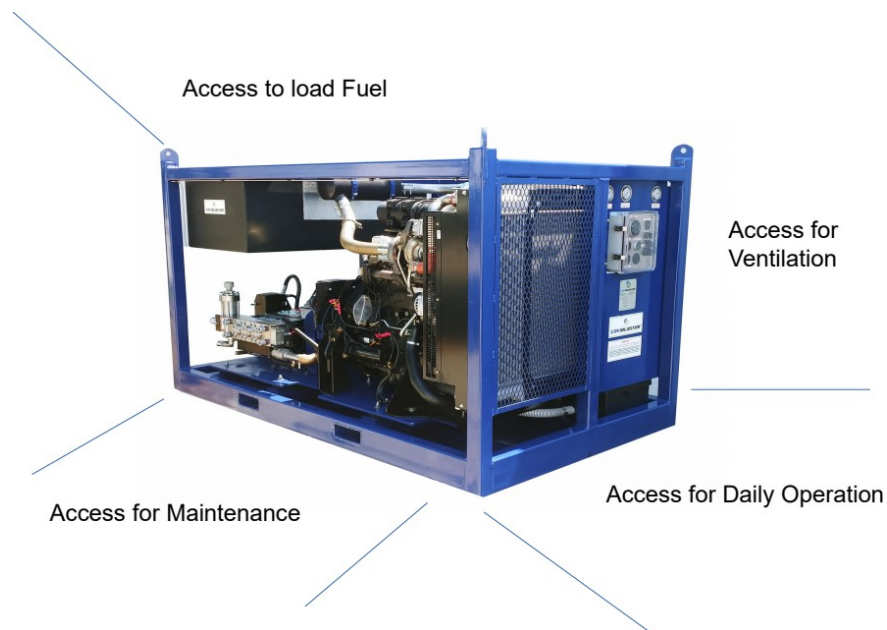

Figure 4.2 – Installation Guidelines

Initial Set-Up:

After first receiving the CaviBlaster Power Unit, the following must be checked and completed:

1. Add engine oil (See **Engine Manual**)
2. Add engine coolant (See **Engine Manual**)
3. Add pump oil (See **Pump Manual**)
4. Connect the feed or suction hose (See **Section 4.3.1**)
5. Connect the pressure hose (See **Figure 2.3**)
6. Fill the fuel tank (Use diesel fuel ASTM Grade No. 1-D or 2-D, or EN 590 or as specified in the **Engine Manual**).



ENGINE AND/OR PUMP FLUIDS MAY HAVE BEEN REMOVED FOR SHIPMENT. CHECK FLUID LEVELS PRIOR TO STARTING.

Connecting the Water Source:

The CaviBlaster power unit can be used with seawater or fresh water. It must be flushed with fresh water for 1-2 minutes after each use in seawater to ensure long service life.



THE CAVIBLASTER 2570-D MUST BE FLUSHED AND RINSED WITH FRESH WATER AFTER EVERY USE IN SEAWATER.



FAILURE TO FLUSH AND RINSE THE POWER UNIT AFTER USE IN SEAWATER WILL RESULT IN INCREASED WEAR AND TEAR ON COMPONENTS AND IN DECREASED SERVICE LIFE.



FAILURE TO FLUSH AND RINSE THE UNIT CAN CAUSE THE PUMP VALVE(S) TO STICK IN THE OPEN POSITION. THIS WILL PREVENT THE SYSTEM FROM PRODUCING THE CORRECT OPERATING PRESSURE.

The feed water inlet connection is located on the end panel (See **Figure 2.3**). A self-priming channel water pump is supplied to provide positive inlet water pressure to the main pressure pump. Two water supply conditions are acceptable for the CaviBlaster power unit.

- Forced inlet water condition using the channel water pump or an outside water source capable of supplying at least 30 GPM (114 LPM) at a maximum pressure of 100-PSI (6.9 BAR).
- Gravity feeding water source (See **Figure 4.4**). Use a hose with a diameter of at least 1" to connect the water tank to the power unit.

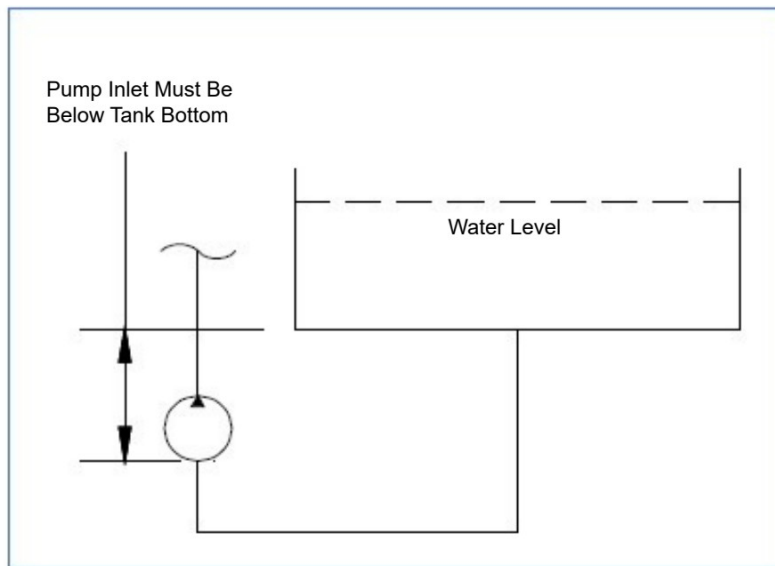

Figure 4.3 – Gravity Feeding Source

To Use the Feed Pump Supplied with the System:

1. Connect the cam-lock socket on the 1-1/2" feed hose to the water inlet connection on the end panel (See **Figure 2.3**).
2. Submerge the feed hose into the water source.
3. Prime the pump by turning on the engine.
4. It is important to keep the feed hose in the water source when the engine is running, and the clutch is engaged or damage to the pressure pump will result.

To Use Force Feed from an Alternate Source:

1. When feeding the CaviBlaster with an alternate water source, the source must supply water at a volume of greater than 30 gallons (114 L/m) at a maximum pressure of 100-PSI (6.9 BAR).
2. Connect a 1-1/2" cam-lock socket on the water supply hose to the water inlet connection on the end panel (See **Figure 2.3**).
3. Turn on the alternate water source.



ENSURE THAT THE FEED HOSE IS CONNECTED TO THE INLET CONNECTION AND THE WATER SUPPLY IS ON PRIOR TO STARTING THE PRESSURE PUMP. FAILURE TO SUPPLY WATER TO THE PRESSURE PUMP WILL CAUSE DAMAGE TO THE PUMP.

To Use Gravity Feed:

1. Locate the water supply tank so that the tank outlet is higher than the water inlet on the control panel (See **Figures 2.3 and 4.4**).
2. Connect a minimum 1-1/2" hose to the water inlet 1-1/2" cam-lock plug.
3. Connect the other end of the hose to the water supply tank outlet.
4. Make sure the lowest point in the hose line is the connection with the power unit.
5. It is essential that adequate water is supplied to the water supply tank to maintain the water level several inches above the tank outlet. Failure to maintain an adequate water level in the supply tank could starve the pressure pump of water causing damage to the seals or other components of the pressure pump.

Ensure that the water source can reliably deliver the required pump flow of 25 gpm (95 LPM). A minimum delivery of 30 GPM (114 LPM) is recommended to ensure that the pump is not starved of water. If connecting to a gravity feed tank, locate the tank outlet above the water inlet connection on the power unit to ensure a flooded suction line (See **Figure 4.4**).

Operation:

The CaviBlaster 2570-D should be operated by two (2) properly trained individuals. One, the diver, operates the zero-thrust gun, while the other operates the power unit. Both operators should be in audio or visual communication with each other.



THE CAVIBLASTER 2570-D SHOULD ONLY BE OPERATED BY PROPERLY TRAINED PERSONNEL WHO ARE FAMILIAR WITH THE CONTENTS OF THE MANUAL. REVIEW THE SAFETY REQUIREMENTS FOUND IN SECTION 3 BEFORE OPERATING.

Preparing the CaviBlaster for Operation:

The following checklist should be completed in advance, so that the unit is always ready for immediate use. This should be completed after each use.

1. Inspect the CaviBlaster power unit, hoses, fittings and zero-thrust gun/guns for any signs of damage.
2. Inspect the inline filter cartridge to ensure that it is not clogged (See **Figure 6.1**). Clean or change cartridge if necessary.
3. Check for proper engine oil level (See **Engine Owner's Manual**). Add lubricating oil (SAE 10W40) if necessary.
4. Check for proper pressure pump oil level (See **Pump Owner's Manual**). Add lubricating oil (SAE 30 non-detergent) if necessary.
5. Check fuel tank (See **Figure 2.1**) for proper diesel fuel level. Add diesel fuel (ASTM Grade No. 1-D or 2-D, or EN 590) if necessary.



INCORRECT FULES SHOULD NOT BE USED AS THEY MAY PROVE HAZARDOUS AND CAUSE DAMAGE TO THE ENGINE.

Startup of the CaviBlaster:

Before starting the CaviBlaster 2570-D Power Unit, review all safety requirements found in **Section 3.0 SAFETY INFORMATION**. This equipment should only be operated by individuals who have read and understand the CaviBlaster Operation and Maintenance Manual.

1. Verify that the unit has been properly prepared for operation as described in **Section 4**.
2. Connect the zero-thrust gun to the high-pressure hose and unroll sufficient length of hose to reach the operating location.
3. Verify that the throttle control is at more than half throttle.
4. Verify that the PTO lever is in the disengaged position.
5. Apply appropriate hearing protection prior to starting engine.
6. Turn the ignition start key to the on position and wait for the glow plugs to heat up. Turn the ignition start key to the start position. If the engine does not start within 10 seconds, turn the ignition start key to the off position and wait at least 30 seconds before trying to start again. Once the engine starts, turn off the ignition start key to the on position.
7. Run the engine at idle speed for a minimum of 20 seconds (20") at operating temperatures above 41°F (5°C). For lower operating temperatures, run at idle speed for a minimum of one minute (1').



DO NOT THROTTLE UP THE ENGINE UNTIL THE DIVER IS READY FOR UNDERWATER OPERATION.



THE ENGINE MUST BE RAN AT FULL THROTTLE / FULL SPEED. IF PARTIALLY THROTTLED, THE ENGINE WILL STALL, CREATING AN UNDESIERABLE RUNNING CONDITION FOR THE BELT DRIVE SYSTEM.

Normal Operation:

Normal operation of the CaviBlaster system is defined as user control of water flow via the bypass gun trigger. Control of the power unit from the gun trigger is accomplished by a mechanical shut-off valve in the gun/guns. Should a problem develop with the control valve, discontinue using the CaviBlaster until fixed.

The CaviBlaster 2570-D Power Unit is designed to operate at full throttle. Less than full throttle will result in malfunction of the belt drive system and less than optimum cleaning performance.



REVIEW THE SAFETY REQUIREMENTS FOR PPE AND SAFE OPERATION BEFORE PROCEEDING.

1. Startup the power unit as described in **Section 5.2**.
2. Verify that the zero-thrust gun is properly connected and that the mechanical trigger is released.
3. When the diver is ready to commence cleaning operations, ensure that the zero-thrust gun is submerged in water. Ensure that the power unit operator and other persons working in the vicinity of the power unit wear appropriate hearing protection when the engine is running. If the diver is not wearing a helmet, hearing protection is recommended. CaviDyne suggests vented earplugs such as “Doc’s Proplugs” for diver hearing protection.
4. Wear neoprene or rubber gloves to protect the hands and follow all safety regulations that may be applicable to the work being performed.
5. The zero-thrust gun trigger should be in open or “ON” position (See **Figure 5.3**) when engaging the PTO and throttling up the engine. This will prevent the pressure pump from being in a loaded condition which will cause the clutch and belt to slip while they are engaging the pressure pump.
6. Pull the PTO handle to the “ON” position to engage the pressure pump.
7. Throttle the engine completely up using the throttle control (See **Figure 5.1**).
8. Activate the cleaning cavitation stream by squeezing the gun trigger to the open or “ON” position (See **Figure 5.3**). Release trigger to stop the water flow at the nozzle and direct it to dump mode.
9. If the diver operating the unit must be replaced or the cleaning operation must be interrupted or terminated, disengage the pressure pump by pushing the throttle lever in to the idle position and pushing the PTO handle to the “OFF” position (See **Figure 2.3**). Release the water pressure in the hose(s) by squeezing the zero-thrust gun trigger to the open or “ON” position (See **Figure 5.3**) while under water. Revert to step 3 of the operating instructions when the diver or replacement is ready to continue cleaning.



ALTHOUGH THE CAVIBLASTER SYSTEM IS SAFE TO USE WHEN SUBMERGED IN WATER, THE SYSTEM GENERATES A HIGH PRESSURE (UP TO 7,000-PSI {482 BAR}) WATER STREAM, WHICH CAN CAUSE INJURY WHEN THE LANCE IS OUT OF THE WATER. ALWAYS KEEP THE LANCE SUBMERGED WHEN THE PRESSURE PUMP IS ENGAGED.

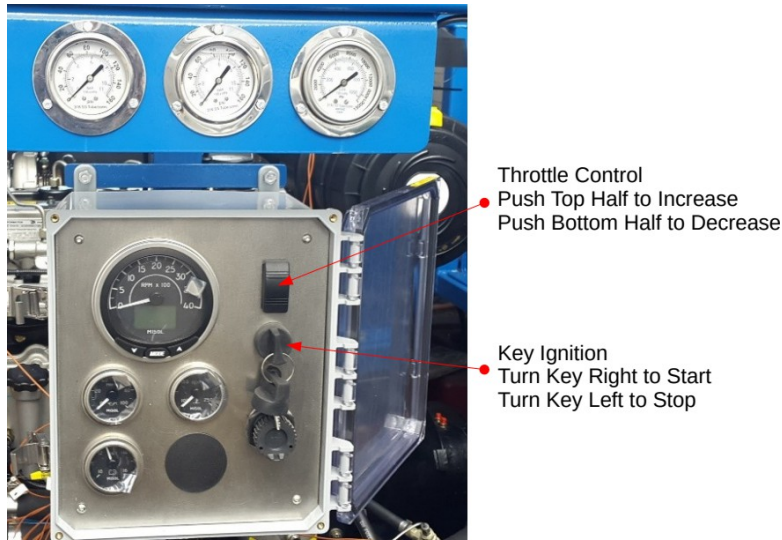

Figure 5.1 – Engine Shut-Down and Throttle Control

NOTE: New generation Diesel engines with emission control requirements at a level “Tier 4F” in USA and “Stage V” in EU governed by computer systems with better electric control and higher redundancy of safety features **DO NOT** require an Emergency Stop Button.

Adjusting the CaviBlaster for Maximum Performance:

The pressure at the nozzle of the zero-thrust gun must be maintained within certain limits to achieve cavitation and for best performance results. The water pressure should be 7,000-PSI (482 BAR) with the zero-thrust gun submerged and the gun trigger in the “ON” position. The power unit operator should turn the knob on top of the pressure regulating valve (See **Figure 5.2**) until pressure reads 7,000-PSI (482 BAR) on the test gauge. Turning the knob clockwise will increase the pressure and turning it counterclockwise will decrease the pressure.

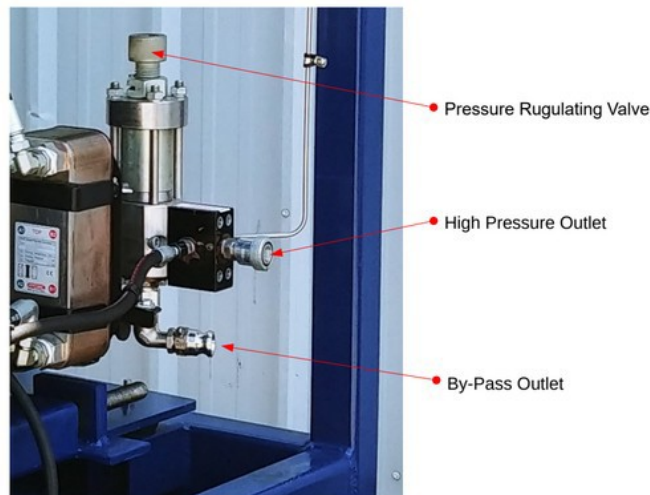

Figure 5.2 – Pressure Regulating Valve

Recommendations for Effective Results:

Once the engine is throttled up to operating speed and the water trigger is pulled, the diver must find the most effective distance between the zero-thrust gun nozzle and the surface being cleaned.

1. Engage the pressure pump by moving the PTO lever (See **Figure 2.3**) to the “ON” position to engage the clutch. Push in the red knob on the control panel (See figure 5.1), press the upper half of the throttle control until the desired engine speed is reached.
2. The most efficient operating technique is to hold the nozzle 2-5 inches (5-12 cm) away from the surface to be cleaned and at a 25-to-45-degree angle to the surface being cleaned (See **Figure 5.3**). The diver needs to observe the shape of the cavitating jet cone. At greater depths, the higher ambient pressure will cause the jet cone to be shorter. The widest zone of the cone is the most efficient part of the cavitating-jet. Placing the nozzle closer than 2 inches (5 cm) from the surface being cleaned will not allow for efficient cavitation performance and will degrade the cleaning capability of the CaviBlaster system.
3. Follow all safety regulations that may be applicable to the work being performed.

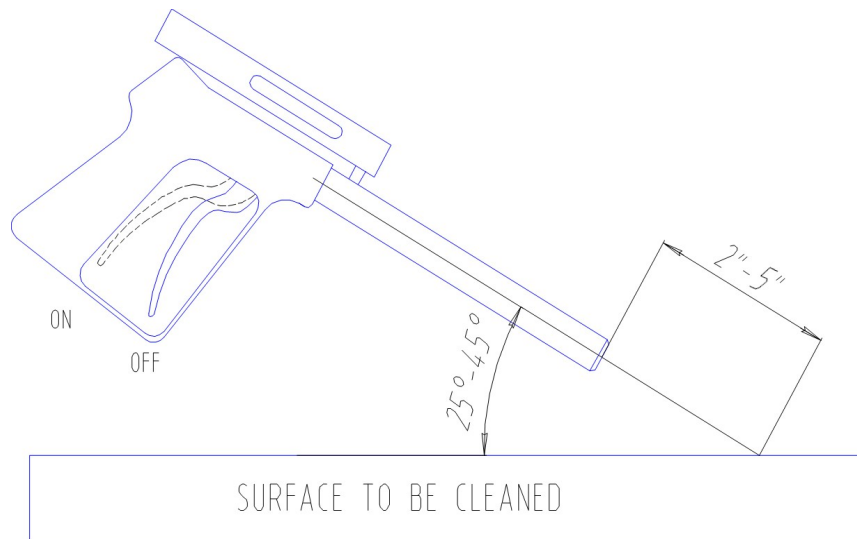

Figure 5.3 – Zero-Thrust Gun Position for Best Results

Shutting Down the CaviBlaster:

1. Adjust the engine speed to idle by pushing on the bottom half of the throttle control (See **Figure 5.1**).
2. Push the PTO handle to the “OFF” position (See **Figure 2.3**). This will disengage the pressure pump.
3. Shut off the engine by turning the ignition key on the control panel to the “OFF” position (See **Figure 5.1**).
4. If using force feed from an alternate source or if using gravity feed, shut off the supply of water to the pressure pump.
5. Squeeze the zero-thrust gun trigger to the open or “ON” position (See **Figure 5.3**) to release the water pressure remaining in the hose(s) while the zero-thrust gun is submerged.
6. It is now safe to remove the zero-thrust gun from the water.
7. Flush the system and rinse the power unit with fresh water at the end of the day.

Emergency Shutdown Systems:

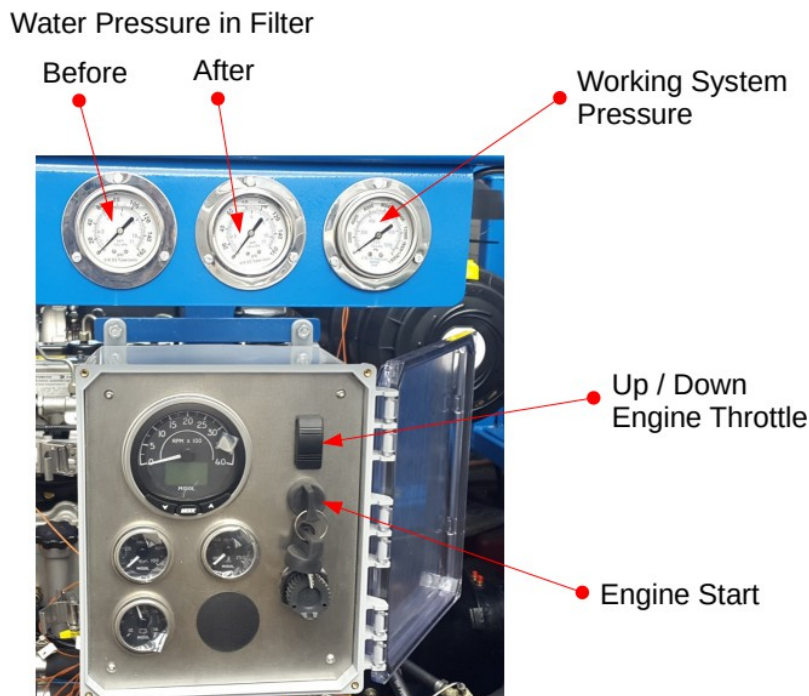

Figure 5.4 – Control Panel Ignition Key

Maintenance:

Maintenance on this unit should be restricted to authorized personal that have been properly trained. Review this manual, especially **Section 3.0 SAFETY INFORMATION**, prior to performing any service on this equipment.



EQUIPMENT MUST BE “OFF” AND PRESSURE RELEASED FROM ALL HOSES PRIOR TO ANY SERVICE WORK.



ONLY REPLACE PARTS WITH THOSE SUPPLIED OR APPROVED BY CAVIDYNE. USE OF ANY OTHER PARTS MAY LEAD TO EQUIPMENT FAILURE AND SEVERE PERSONAL INJURY AND WILL VOID ALL WARRANTIES.



THE CAVIBLASTER 2040-D MUST BE FLUSHED AND RINSED AFTER EACH USE IN SEA WATER



FAILURE TO FLUSH AND RINSE THE UNIT CAN CAUSE THE PUMP VALVE(S) TO STICK IN THE OPEN POSITION. THIS WILL PREVENT THE SYSTEM FROM PRODUCING THE CORRECT OPERATING PRESSURE.



FAILURE TO FLUSH AND RINSE THE UNIT WILL RESULT IN PREMATURE WEAR AND TEAR ON THE COMPONENTS AND DECREASED SERVICE LIFE.

Basic Preventive Maintenance Recommendations:

Task	After Every Use	Monthly	Every 12 Months or 250 Hours	Every 12 Months or 500 Hours	Every 3 Years or 1500 Hours
Check engine oil level and add if low	X				
Check pump oil level and add if low	X				
Check coolant level and add if low	X				
Check drive belt for wear and replace if worn	X				
Check in-line strainer cartridge and filter and clean if necessary	X				
Inspect hoses for wear or damage ¹	X				
Check zero-thrust gun trigger for leakage and replace if necessary ²		X			
Check feed pump belt tension		X			
Replace engine oil ³			X		
Replace engine fuel filter cartridge				X	
Replace engine air filter				X	
Replace engine oil filter ³				X	
Replace pump oil ⁴				X	
Replace engine fan and feed pump belts				X	

* Whichever occurs first.

- 1) If any hose damage is found, replace hose immediately.
- 2) Remove zero-thrust gun from water with system at operating pressure and trigger in the closed or "OFF" position. If water is leaking out of barrel or handle, the valve is worn and should be replaced.
- 3) The initial oil and filter change is after 50 hours of operation. The oil change interval is every 125 hours if oil of a quality lower than prescribed by the manufacturer or high-sulfur fuel is used. See engine manufacturer's literature in the Appendix for additional recommendations.
- 4) The initial oil change is after 50 hours of operation. The oil change interval is every 300 hours if oil other than CAT Pumps oil is used. See pump manufacturer's literature in the Appendix for additional recommendations.
- 5) Lubricate PTO in accordance with instructions on PTO information plate affixed to PTO.

Diesel Engine Service:

The diesel engine requires routine maintenance. Oil must be checked and changed regularly. Oil, air and fuel filters must be checked and changed regularly. The engine crankcase and oil filter hold 3.5 gal. (13.2 L) of SAE 10W30 or 15W40 viscosity lubricating oil. For detailed information on these routine maintenance requirements as well as other service recommendations, see the engine manufacturer's literature.

Pump Service:

The high-pressure water pump requires minimal maintenance. The pump oil should be checked on a regular basis. The pump crankcase holds 4.2 gal. (16.0 L) of SAE 30 (ISO-68) viscosity non-detergent lubricating oil. See pump manufacturer's literature.

Inspection/Cleaning of Water Inlet Strainer:

The CaviBlaster 2570-D is equipped with a water strainer located between the water feed pump and the pressure pump. To inspect and clean the strainer, follow the procedure below:

1. Isolate or disconnect the water source from the inlet connection to the power unit.
2. Unscrew the filter housing (turn counterclockwise).
3. Pull filter bowl down.
4. Remove the strainer.
5. Inspect the strainer and flush any debris with clean water.
6. Rinse any debris out of filter bowl.
7. Push strainer back into housing.
8. Push the bowl back onto filter housing.
9. Thread the housing clockwise by hand to tighten.

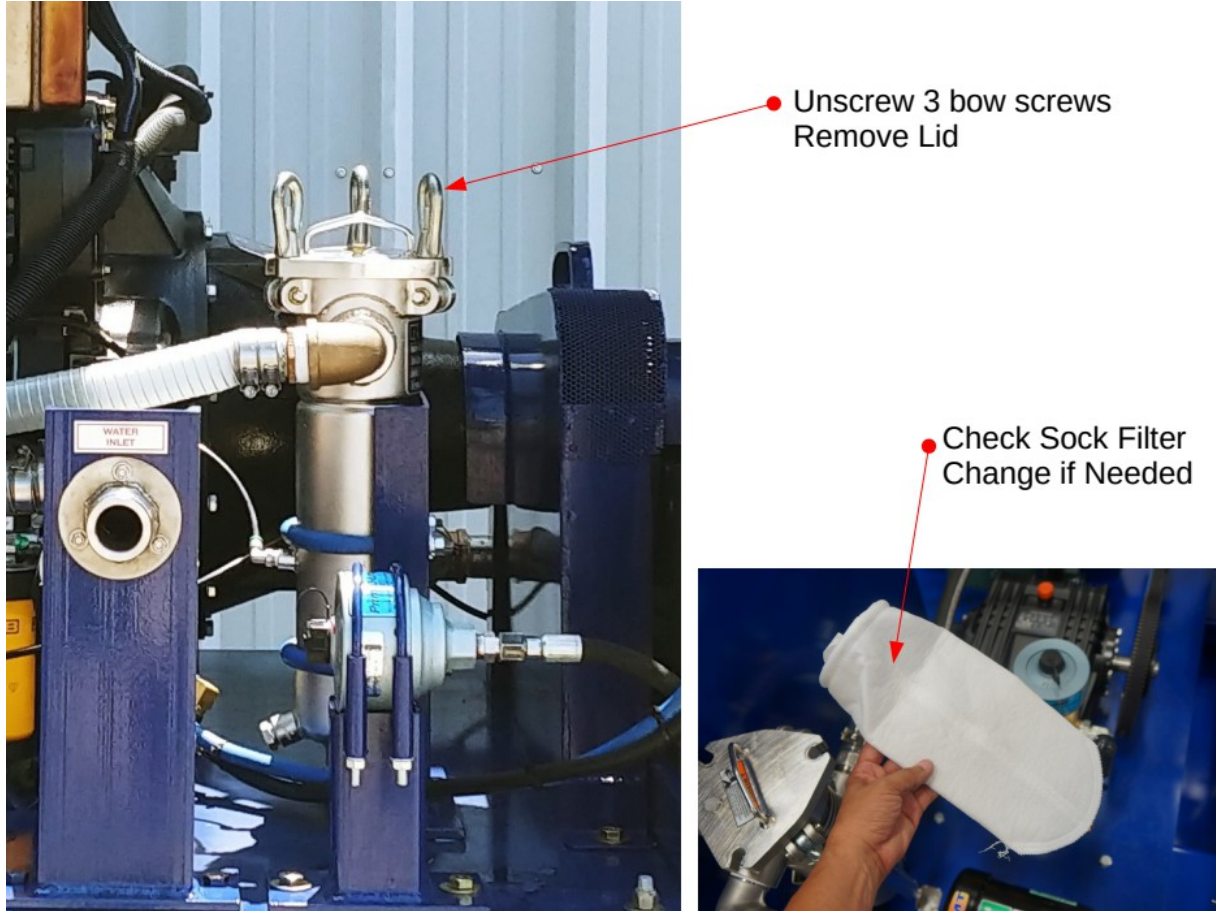

Figure 6.1 – Inspection / Cleaning Water Strainer

Inspection / Maintenance of the Belt Drive System:

The CaviBlaster 2570-D is equipped with belt power transmission. The driver shaft has a manually operated power take-off (PTO).



FULL ENGINE SPEED IS REQUIRED FOR PROPER OPERATION OF BOTH THE CLUTCH AND THE LANCE.

To Inspect the Belt:

1. Remove the belt guard cover (See **Figure 6.2**).
2. If belts need tightening, use the tightening nut to adjust (See **Figure 6.2**).
3. Release the bolts holding the pump rails.
4. Adjust Belt tension.
5. Tighten pump rail bolts.
6. Replace belt guard cover.

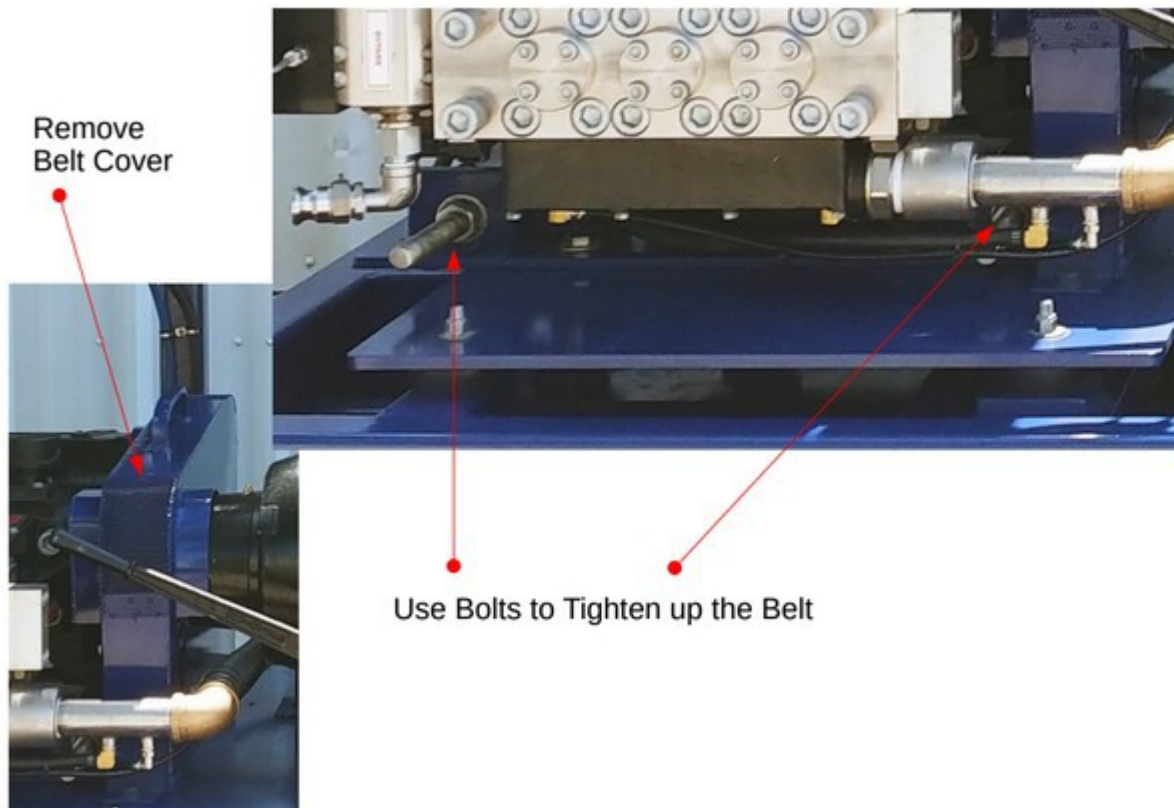

Figure 6.2 – Inspection / Belt Tension

Inspection / Maintenance of the Zero-Thrust Gun

In order to minimize potential problems with the Zero-Thrust Gun it is recommended that the gun be treated at the end of each work period:

1. Flush and rinse the gun with fresh water after each use in sea water.
2. Place the gun in a container of clean, fresh water if it will be used in the next 24 hours. Ensure the gun is completely submerged.
3. If the gun will not be used for a period of several days, remove the super swivel from the gun handle and, with the gun turned upside-down, pour approx. 5ml of lubricating oil into the water inlet while opening and closing the trigger. This will allow oil to reach the positioning pin and valve cone and minimize the possibility of corrosion or mineral crystals forming that would freeze the pin or valve cone.
4. Do not use WD-40 for long term storage.



Figure 6.3 – Diver Gun 2570 ZT-DumpGun

Winterization:

The power unit should be winterized if stored at temperatures below 32 degrees Fahrenheit (0 degrees Celsius).

Total system displacement with 100 ft of hose (optional): 4.3 gallons

Total system displacement without hose: 2.0 gallons

To winterize the CaviBlaster 2570-D power unit:

1. Fill a 5 gallon or larger tank with appropriate antifreeze solution.
2. Insert a feed pump into the antifreeze tank.
3. Start the unit and make sure the pump is primed.
4. Attach a minimal amount of pressure hose and direct the outlet of the hose into the antifreeze tank.
5. Run the unit without zero-thrust gun attached until antifreeze comes out of the end of the hose for 10 seconds.
6. Stop the unit.
7. Following this procedure will ensure that all the critical system components exposed to water have been flushed with antifreeze.

Troubleshooting:

ENGINE DOES NOT TURN OVER

- Verify that battery connections are tight

ENGINE TURNS OVER BUT DOES NOT START

- Check fuel level
- Check fuel filter
- Check fuel line for air lock
- Verify that fuel pump solenoid is not stuck

ENGINE THROTTLES UP, BUT STALLS AFTER FEW SECONDS

- Verify that drive belt is tensioned (follow procedures in **Section 6.5**)
- Check that pressure regulator / unloader switches to by-pass mode

ENGINE SPEEDS UP, BUT WATER DOES NOT GO OUT THE ZERO- THRUST GUN

- Verify inlet water supply is functioning
- Ensure that the power unit is not located too far above the water level, exceeding the capacity of the feed pump
- Check that feed pump inlet water strainer is clear
- Check for leaks in the water lines
- Check for an airlock in the water inlet lines
- Verify that the feed pump is delivering water Pump mechanical failure
- Pump drive belt failure
- Check that pressure pump inlet and discharge valves are not stuck open (common problem if not flushed after use with sea water)
- Check for water going out of the bypass – pressure regulator failure

WATER IN CRANK CASE

- Check the pump seals for damage (feeding water at greater than 100-PSI (6.9 BAR) can force water past the seals and damage the seals; starving the pressure pump of water can overheat and damage the seals)
- Check the plungers for cracks
- Check the plunger rod O-ring for damage

ZERO-THRUST GUN IS NOT CLEANING PROPERLY

- Verify that the system is operating at the correct pressure (7,000-PSI)
- Remove the zero-thrust gun from water with the system at operating pressure and trigger in the closed or “OFF” position. In this mode it is normal for water to flow from the dump outlet and be leaking out of the cleaning nozzle. If it is not, replace the trigger valve assembly.
- With the trigger valve in the “ON” position water should flow only from the cleaning nozzle. If it flows from the gun handle or the dump nozzle the trigger valve assembly should be replaced.
- Check cavitation and zero-thrust nozzles for foreign particles Visual inspection
- Insert a small wire into nozzle orifices to check for obstruction(s)
- Remove trigger valve assembly and “backflush” with compressed air or pressurized water



WARNING: ENSURE THAT NEITHER THE CLEANING NOZZLE NOR DUMP OUTLET OF THE GUN IS NOT POINTING AT ANY STRUCTURE, EQUIPMENT, POWER LINES OR PERSONNEL WHEN IT IS OUT OF WATER. SERIOUS INJURY OR DEATH COULD OCCUR IF THE GUN TRIGGER IS TURNED TO THE “ON” POSITION AND THERE IS NOT A MINIMUM OF 60FT (22M) OPEN, CLEAR SPACE IN FRONT OF AND BEHIND THE GUN.

Replacement Parts:

CaviBlaster 2570-D Power Unit Replacement Parts			
Recommended Order Qty.:	Recommended Order Qty.:	Recommended Order Qty.:	Recommended Order Qty.:
1	1	Inlet strainer cartridge	
1	1	Engine air filter	
2	1	Engine oil filter	
1	1	Engine fuel filter	
1	1	Engine fan belt	
2	1	Feed pump drive belt	
2	1	Pressure pump drive belt	
1	1	Pump oil seal kit	09554
1	1	Pump plunger packing kit	09707
1	1	Pump inlet valve kit	09709
1	1	Pump discharge valve kit	09710
1	1	Pressure regulating unloader repair kit	UB 402 / K
1	1	Relief valve repair kit	UB 402 / K
1	1	Trigger valve repair kit	20 3600 490

