



CaviBlaster 1030-ROV

Operation & Maintenance Manual





CAVIDYNE, LLC IS NOT RESPONSIBLE FOR DAMAGES OR INJURY RESULTING FROM FAILURE TO COMPLY WITH INSTRUCTIONS IN THIS MANUAL. PLEASE READ THE ENTIRE MANUAL CAREFULLY BEFORE USE.



COMMERCIAL DIVER'S GEAR SHOULD BE USED TO OPERATE THE CAVIBLASTER SYSTEM.



THIS EQUIPMENT GENERATES HIGH PRESSURE WATER AND IS INTENDED FOR UNDERWATER USE ONLY. SERIOUS PERSONAL INJURY OR DEATH MAY RESULT FROM IMPROPER USE.

Unit Specifications:

The CaviBlaster 1030-ROV Power Unit consists of a 28HP (19 kW) Permco hydraulic gear motor power-pack and a UDOR GSC34/15 Triplex Plunger Pump.

Detailed performance and specifications are listed below:

CaviBlaster 1030-ROV Specifications	
Nominal Pump Flow	17 GPM (65 LPM)
Nozzle Operating Pressure	3,000-PSI (207 BAR)
Driver	28 HP Hydraulic Gear Motor
Installation Environment	Submersible
Hydraulic Oil Flow Requirements	*See below.
Overall Unit Dimensions (L x W x H)	23-1/4" x 20" x 9-1/2" (59 cm x 50.8 cm x 23.1 cm)
Maximum Pressure Hose Length	300 LF (100 meters) of 1/2" (1.3 cm) diameter
Power Unit Weight (Dry)	131 LBS (54.5 KG)

**Hydraulic Power Unit must be capable of operating the water pressure pump at 1450 RPM and 21 HP. Consult CaviDyne regarding your existing Hydraulic Power Unit capabilities.*

Figure 1.1 – CaviBlaster 1030-ROV Specifications

General Description:

The CaviBlaster 1030-ROV high-pressure waterpower Unit allows the operator to use the water flow and pressure to generate cavitation at the end of the proprietary nozzle.

The CaviBlaster cleans the surface of any underwater structure using the energy released by the implosion of the bubbles during the cavitation process. When directed at the surface being cleaned, the energy released by the collapsing bubbles causes marine growth to be removed from the surface.

The system consists of a portable high-pressure pumping unit designed for submersible ROV use and a high-pressure cavitation lance (connected to ROV manipulator) with connecting high pressure hose.

The system is normally supplied with an integral pressure compensator, pressure compensation can also be achieved using the ROV onboard pressure system, consult with CaviDyne LLC for acceptable pressure compensations options.

The CaviBlaster 1030-ROV Power Unit is a complete “plug and play” system built on a supporting platform that allows quick deployment and/or installation of the unit. Water is supplied directly from the unit operating environment.

The unit is equipped with many features to maintain safety while operating at pressures of 3,000-PSI (207 BAR).

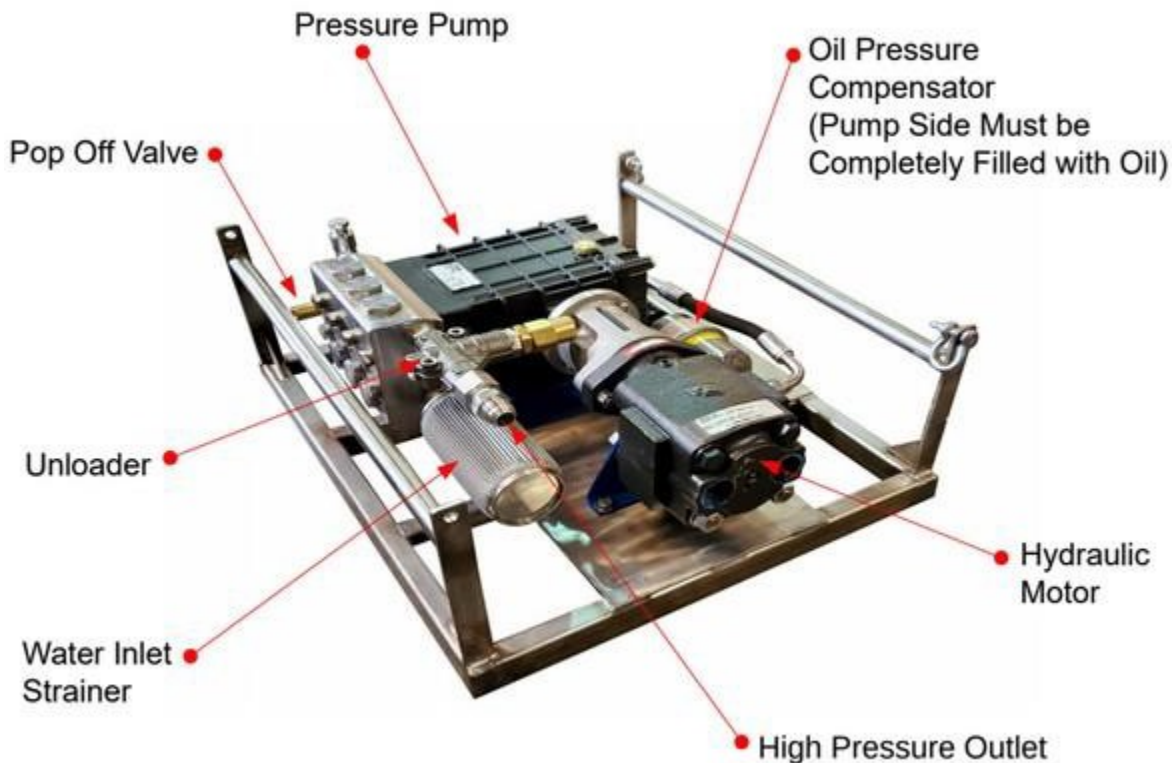

Figure 2.1 – CaviBlaster 1030-ROV General Features

Using This Manual:

While every effort has been made to ensure the accuracy and completeness of the content of this documentation, CaviDyne, LLC, its employees or associated organizations shall have neither liability nor responsibility to any person or entity with respect to any loss or damage arising from its use. Always take appropriate and adequate precautions to prevent damage or injury. Should you, at any time, have questions or concerns, please, contact our headquarters, as we will be happy to assist you. While quality and your satisfaction are our goal, nothing takes precedence over your safety.

Safety Information:

The CaviBlaster 1030-ROV Power Unit is an inherently powerful and potentially dangerous piece of equipment; however, with proper care and training it can be operated safely. The 1030-ROV must only be operated by personnel that have read and understand this manual. It is intended to reinforce and review safety techniques to prevent personal injuries and property damage.

Users must comply with all local, state, and national laws concerning high-pressure water jetting equipment as well as all underwater work regulations.

It is strongly recommended that this entire manual be reviewed in-depth before operating or servicing this equipment. Service work should only be performed by individuals who are proficient in using this equipment. Refer to the applicable section in this manual for the correct procedures prior to any installation, setup, or maintenance work.

NOTE: The oil pressure compensator is not a pressurized component and therefore not a safety hazard. It is open at one end and connected to the pressure pump oil chamber at the other end. Its purpose is simply to balance the oil pressure in the water pressure pump with the unit's surrounding environmental pressure to prevent damage to the water pressure pump.

Personal Safety:

Operation of the CaviBlaster 1030-ROV underwater submersible ROV-mounted cleaning system must only be operated by personnel who have been trained in its use. Operation of the system without the proper training can result in property damage and damage to the CaviBlaster unit.



CAVIDYNE, LLC IS NOT RESPONSIBLE FOR DAMAGES OR INJURIES RESULTING FROM A FAILURE TO COMPLY WITH INSTRUCTIONS IN THIS MANUAL. PLEASE READ AND STUDY THE ENTIRE MANUAL CAREFULLY BEFORE USE.



IF MAINTENANCE OR REPAIR OF THE CAVIBLASTER GUN IS BEING CONDUCTED OUT OF THE WATER, REMEMBER THAT THE ZERO-THRUST GUN HAS FRONT AND REAR JETS. NEVER DIRECT THE JET STREAMS AT A PERSON OR ANIMAL, OR TOWARD POWER LINES OR OTHER HIGH VOLTAGE EQUIPMENT.



ENSURE THAT THERE IS A SAFE AREA TO WORK WHILE OPERATING THE CAVIBLASTER 1030-ROV



SEEK IMMEDIATE MEDICAL ATTENTION IF THE OPERATOR SUFFERS AN INJURY AS THE RESULT OF CONTACT WITH THE HIGH-PRESSURE WATER STREAM. SERIOUS PERSONAL INJURY CAN RESULT FROM AN UNTREATED WATER INJECTION WOUND.

Personal Protective Equipment:

Always wear appropriate Personal Protective Equipment (PPE) when operating this equipment.

Personnel operating or working in the vicinity of the power unit should wear appropriate hearing protection when the CaviBlaster system is in use. If the diver is not wearing a diving helmet, hearing protection is recommended. CaviDyne, LLC. recommends wearing vented earplugs such as “Doc’s Pro-plugs” for diver hearing protection.

The operators of the CaviBlaster system should always wear neoprene or heavy rubber gloves to provide protection to the hands and nails. The gloves will absorb most of the energy produced by bursting cavitation bubbles and prevent the cavitation bubbles from contacting the operators’ hands. The gloves will also protect operators’ hands from the initial shockwave when the zero-thrust gun is activated.



FAILURE TO WEAR APPROPRIATE PPE MAY RESULT IN PERSONAL INJURY.

Modification to the Equipment:

Do not make any unauthorized modifications or repairs to this equipment. Components used throughout this assembly were specifically designed or selected to safely meet the unique high-pressure requirements. Only replace parts with those recommended by or supplied by CaviDyne. Any unapproved modifications will void the equipment warranty. Unauthorized modification or part substitution can result in serious personal injury or property damage.



UNAUTHORIZED REPLACEMENT OF ANY PART MAY LEAD TO CATASTROPHIC EQUIPMENT FAILURE AND SERIOUS PERSONAL INJURY.

Installation:

The CaviBlaster 1030-ROV must be securely attached to the ROV using the vibration mounts supplied or other secure fastening mechanism.

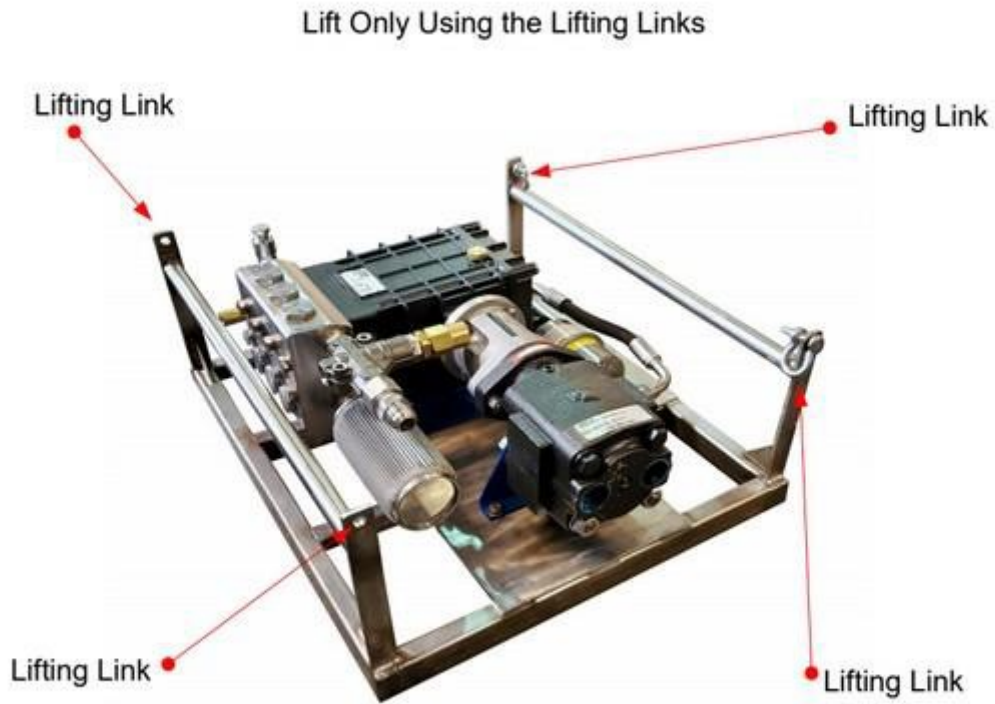

Figure 4.1 – Lifting Guidelines

Initial Set-Up:

After first receiving the CaviBlaster Power Unit, the following must be checked and completed: See **Figure 2.1** for item locations.

1. Add oil to the pump by completely filling the pump to the top of the fill port.
2. Stand unit on end with pump at bottom.
3. Remove oil pressure compensator fill port cap.
4. Fill the oil pressure compensator and hose with oil.
5. Allow the unit to sit for several minutes to allow any trapped air to escape.
6. Top off oil pressure compensator as required.
7. Put the oil pressure compensator fill port cap back on.
8. Set the unit back down.
9. Connect hydraulic Power Unit hoses.
10. Connect the water pressure hose.



MOTOR AND/OR PUMP FLUIDS HAVE BEEN REMOVED FOR SHIPMENT. CHECK FLUID LEVELS PRIOR TO STARTING. THERE CAN BE NO TRAPPED AIR IN THE UNIT FOR PROPER OPERATION.



THE CAVIBLASTER 1030-ROV CAN BE USED WITH SEAWATER BUT MUST BE FLUSHED AND RINSED WITH FRESH WATER AFTER EVERY USE IN SEAWATER. FAILURE TO FLUSH AND RINSE THE POWER UNIT AFTER USE IN SEAWATER WILL RESULT IN INCREASED WEAR AND TEAR ON COMPONENTS AND CAN CAUSE THE PUMP VALVE(S) TO STICK IN THE OPEN POSITION. THIS WILL PREVENT THE SYSTEM FROM PRODUCING THE CORRECT OPERATING PRESSURE.

The CaviBlaster 1030-ROV should only be operated by properly trained personnel who are familiar with the contents of the manual. Review the safety requirements found in Section 3.0 before operating.

Preparing the Unit for Operation:

The following checklist should be completed in advance, so that the unit is always ready for immediate use. This should be completed after each use.

1. Inspect the CaviBlaster Power Unit, electric power cord, hoses, JIC fittings and lance for any signs of damage.
2. Inspect the water inlet strainer to ensure that it is not clogged (See Figure 2.1). Clean if necessary.
3. Check for proper pressure pump oil level. Add oil (SAE 30 non-detergent) if necessary.
PUMP MUST BE COMPLETELY FILLED.



INCORRECT OILS SHOULD NOT BE USED AS THEY MAY DAMAGE THE EQUIPMENT.

Startup of the CaviBlaster:

Before starting the CaviBlaster 1030-ROV unit, review all safety requirements found in **Section 3.0 SAFETY INFORMATION**. This equipment should only be operated by individuals who have read and understand the CaviBlaster Operation and Maintenance Manual.

1. Verify that the unit has been properly prepared for operation as described in **Section 4**.
2. Verify that the lance is properly connected to the CaviBlaster and the ROV.
3. Run the ROV hydraulic system to verify that the CaviBlaster hydraulic motor and pressure pump are functioning correctly.

Normal Operation:

Normal operation of the CaviBlaster system is defined as user control of water flow via the lance. In the absence of a diver, control of the Power Unit is accomplished by the ROV manipulator. Should a problem develop with the control valve, discontinue using the CaviBlaster until fixed.



REVIEW THE SAFETY REQUIREMENTS FOR PPE AND SAFE OPERATION BEFORE PROCEEDING.

1. The ROV hydraulic system needs to be operating at a capacity that matches the water pressure pump requirements for the CaviBlaster 1030-ROV to function correctly. Unlike gasoline or diesel engines, a hydraulic motor will run as fast as the oil supply it receives, which means that the hydraulic oil supply must be adjusted to match the water pressure pump requirements. Consult with CaviDyne LLC to determine if your high-pressure oil supply unit is suitable for the CaviBlaster 1030-ROV.
2. Please see flow requirements in the corresponding spec sheet.
3. Activate the cleaning cavitation stream by turning "ON" the hydraulic Power Unit.



ALTHOUGH THE CAVIBLASTER SYSTEM IS SAFE TO USE WHEN SUBMERGED IN WATER, THE SYSTEM GENERATES A HIGH-PRESSURE (UP TO 3,000-PSI [207 BAR]) WATER STREAM, WHICH CAN CAUSE INJURY WHEN THE LANCE IS OUT OF THE WATER. ALWAYS KEEP THE LANCE SUBMERGED WHEN THE PRESSURE PUMP IS ENGAGED.

Adjusting the CaviBlaster for Maximum Performance:

The pressure at the nozzle of the lance must be maintained within certain limits to achieve cavitation and for best performance results. If using a calibration pressure gauge situated between the pressure hose and the CaviBlaster lance, the water pressure should be 3,000-PSI (207 BAR) with the lance submerged and the hydraulic Power Unit operating. For best results, repeat this calibration procedure if cleaning performance degrades, or every 3 months at a maximum.



A CALIBRATION GAUGE IS RECOMMENDED WITH EVERY UNIT. CONNECT BETWEEN THE END OF THE HOSE AND THE LANCE. SEE FIGURE 5.2.

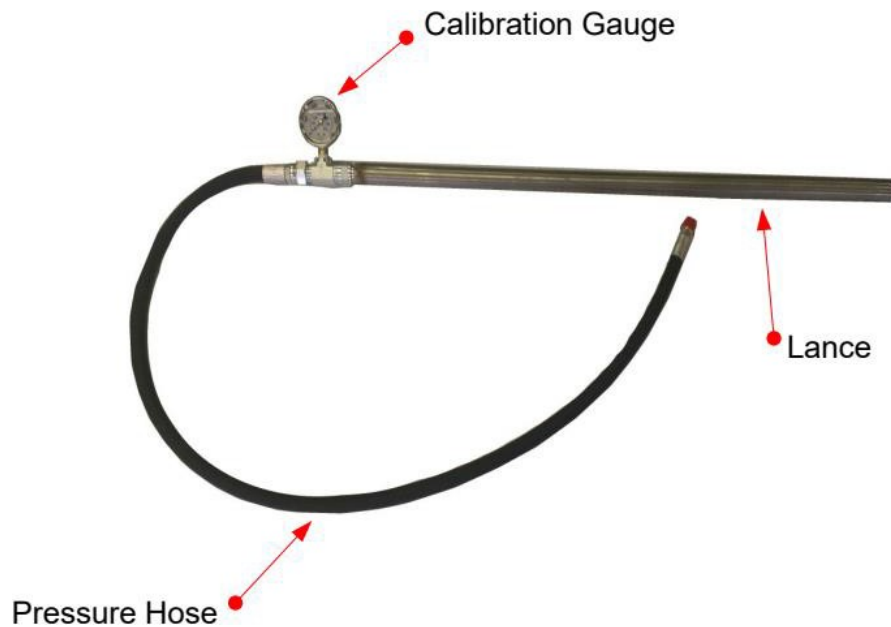

Figure 5.2 – Lance Pressure Calibration

To Calibrate the Pressure at the Zero-Thrust Gun, Follow the Procedure Below:

1. Stop the hydraulic Power Unit to discharge any residual pressure in the hose lines.
2. Disconnect the lance from the main hose line.
3. Attach the calibration gauge between the main hose line and the lance and tighten the JIC connections (See **Figure 5.1**).
4. Submerge the lance. Because of the danger of the operator coming in contact the water stream from the cavitating nozzle, CaviDyne does **NOT** recommend calibrating the lance out of the water. Use extra care to avoid the water stream if doing so.
5. Ensure that the cavitation nozzle is pointed away from the diver's or operator's hands, arms and body.
6. Start the hydraulic Power Unit.
7. Hold the lance tight and observe the calibration gauge (See **Figure 5.1**).
8. Turn the knob on top of the pressure regulating valve (See **Figure 5.1**) until pressure reads 3,000-PSI (207 BAR) on the calibration gauge. Turning the knob clockwise will increase the pressure and turning it counterclockwise will decrease the pressure.

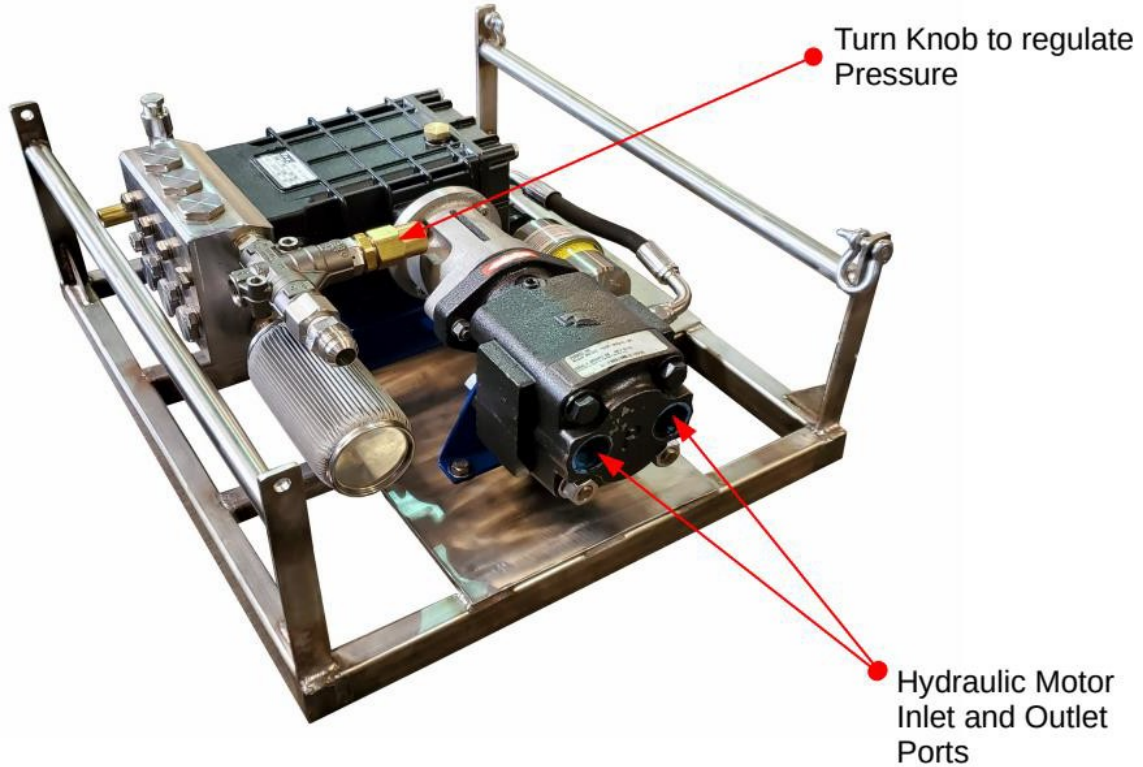

Figure 5.1 – Hydraulic Connections



DO NOT ADJUST THE PRESSURE AT THE LANCE TO MORE THAN 3,000-PSI (207 BAR). HIGHER PRESSURE WILL NOT IMPROVE PERFORMANCE.



HOSE LINES ARE RATED FOR 4,000-PSI (276 BAR). PRESSURES ABOVE 4,000-PSI (276 BAR) COULD RESULT IN PUMP AND / OR HOSE FAILURE

Recommendations for Effective Results:

When the ROV operator is ready to commence cleaning operations, verify that the lance is securely attached to the manipulator.

Once the hydraulic Power Unit is operational and the water jet stream is flowing from the lance, the ROV operator must find the most effective distance between the lance nozzle and the surface being cleaned (See **Figure 5.3**).

1. Engage the ROV's hydraulic Power Unit to activate the CaviBlaster unit.
2. The most efficient operating technique is to hold the nozzle 2-5 inches (5-12 cm) away from the surface to be cleaned and at a 25-to-45-degree angle to the surface being cleaned (See **Figure 5.3**). The ROV operator needs to observe the shape of the cavitating jet cone. At greater depths, the higher ambient pressure will cause the jet cone to be shorter. The widest zone of the cone is the most efficient part of the cavitating jet. Placing the nozzle closer than 2 inches (5 cm) from the surface being cleaned will not allow for efficient cavitation performance and will degrade the cleaning capability of the CaviBlaster system.
3. Follow all safety regulations that may be applicable to the work being performed.

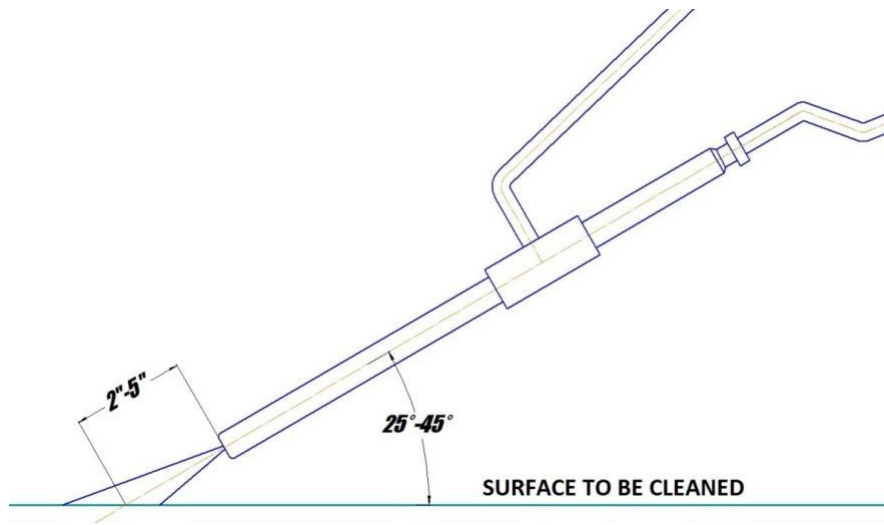

Figure 5.3 – Lance Position for Best Cleaning Results

Shutting Down the CaviBlaster 1030-ROV:

1. Shut down the ROV hydraulic Power Unit, this will turn off the pressure pump and relieve pressure in the system.
2. It is now safe to remove the lance from the water.
3. Flush the system and rinse the Power Unit with fresh water at the end of the day or work shift.

Maintenance:

Maintenance on this unit should be restricted to authorized personal that have been properly trained. Review this manual, especially **Section 3.0 SAFETY INFORMATION**, prior to performing any service on this equipment.



FAILURE TO FLUSH AND RINSE THE UNIT WILL RESULT IN PREMATURE WEAR AND TEAR ON THE COMPONENTS AND DECREASED SERVICE LIFE.



EQUIPMENT MUST BE “OFF” AND PRESSURE RELEASED FROM ALL HOSES PRIOR TO ANY SERVICE WORK.



ONLY REPLACE PARTS WITH THOSE SUPPLIED OR APPROVED BY CAVIDYNE, LLC. USE OF ANY OTHER PARTS MAY LEAD TO EQUIPMENT FAILURE AND SEVERE PERSONAL INJURY



FAILURE TO FLUSH AND RINSE THE UNIT CAN CAUSE THE PUMP VALVE(S) TO STICK IN THE OPEN POSITION. THIS WILL PREVENT THE SYSTEM FROM PRODUCING THE CORRECT OPERATING PRESSURE.



THE CAVIBLASTER 1030-ROV MUST BE FLUSHED AND RINSED AFTER EACH USE IN SEA WATER.

Basic Preventive Maintenance Recommendations:

Task	Before and After Every Use	Every 6 Months or 125 Hours*	Every 12 Months or 250 Hours*	Every 12 Months or 500 Hours*	Every 1,000 Hours
Ensure pump and oil pressure accumulator are filled with oil	X				
Check water inlet strainer cartridge and clean if necessary	X				
Inspect hoses for wear or damage 1	X				
Replace pump oil 2				X	
Check pump valves and seals for wear & change if necessary					X

* Whichever occurs first.

1. If any hose damage is found, replace hose immediately.
2. The initial oil change is after 50 hours of operation. See pump manufacturer's literature in the Appendix for additional recommendations.

Pump Service:

The high-pressure water pump requires minimal maintenance. The pump oil level should be checked on a regular basis. The pump crankcase should be COMPLETELY FILLED with SAE 30 viscosity non-detergent oil.

Inspection/Cleaning of Water Inlet Strainer:

The water inlet strainer should be inspected after each use of the CaviBlaster 1030-ROV.

Troubleshooting:

WATER IN CRANK CASE

- Check the pump seals for damage
- Check the plungers for cracks
- Check the plunger rod O-ring for damage
- Check oil pressure compensator bladder for damage

LANCE IS NOT CLEANING PROPERLY

- Remove the CaviBlaster unit from the water and mount the lance securely in a vice or test stand. Make sure the lance is pointed away from any personnel and any electrical systems or components in the area. The water jet from the lance can travel 30-40 feet (9 to 12 meters).
- Connect the hydraulic motor to a hydraulic Power Unit and start the hydraulic Power Unit. Verify that the hydraulic Power Unit is delivering the correct RPM (1450) and HP (21) required to operate the water pressure pump.
- If water is leaking out of the hose, fittings or connections replace the damaged component and securely tighten all connections.
- If water is leaking from the lance body, contact CaviDyne for further instructions.
- Check lance and nozzle for foreign particles.
- Visual inspection:
 - Insert a small wire into nozzle orifices to check for obstruction(s) and “backflush” with compressed air or pressurized water.

Replacement Parts:

CaviBlaster 1030-ROV Power Unit Replacement Parts			
Recommended Order Qty.:	Qty. Per Assembly:	Part Description:	Part Number:
1	1	Water Inlet Strainer	CASS-20-1-100-316
1	1	Pump Seal Kit	UD-99
1	1	Pump Valve Kit	UD-116
1	1	Pump Stainless Kit	UD-117
1	1	Pump Plunger Rod O-Ring Kit	UD-119
1	1	Regulating Unloader Repair Kit	UB 402 / K
1	1	Relief Valve Repair Kit	UB 402 / K
1	1	Oil Pressure Compensator	S245A1QTTB3
1	1	Oil Fill Hose with Fittings	06-011-0-A106- SS
1	1	Hytrell Spider	16624329-24/32