



CaviBlaster 2040-ROV-M2

Operation & Maintenance Manual





CAVIDYNE, LLC IS NOT RESPONSIBLE FOR DAMAGES OR INJURY RESULTING FROM FAILURE TO COMPLY WITH INSTRUCTIONS IN THIS MANUAL. PLEASE READ THE ENTIRE MANUAL CAREFULLY BEFORE USE.



THIS EQUIPMENT GENERATES HIGH PRESSURE WATER AND IS INTENDED FOR UNDERWATER USE ONLY. SERIOUS PERSONAL INJURY OR DEATH MAY RESULT FROM IMPROPER USE.



THE CAVIBLASTER 2040-ROV-M2 MUST ONLY BE OPERATED AND MAINTAINED BY TRAINED PERSONNEL.

Unit Specifications:

The CaviBlaster 2040-ROV-M2 Power Unit consists of a Dynaset High Pressure Water Pump HPW- 320.

DYNASET HPW Pump converts the hydraulic oil flow of a base machine into high pressure water.

The power of the pump is defined by flow rate and pressure. Actuating power is supplied from the hydraulic system of the base machine or other hydraulic installation.

The relationship between hydraulic oil flow and pressure to pumping fluid flow and pressure is linear. HPW pumps can be safely operated in power range of 0-100%.

For under water use the center body and the heads are made of stainless steel. Plugs are made of stainless steel; bolts are made of stainless steel or with special coating.

Automatic Load Sensing Control on PT-flange. It is useful when hydraulic flow and pressure is occasionally needed. Off-state drives main hydraulic pump via LS-line to 0 ° angle and on-state drives hydraulic pump to full angle, producing maximum oil flow to the HPW pump. This function saves significantly energy and customer's expenses preventing excessive part wear in long term.

Detailed performance and specifications list:

CaviBlaster 2040-ROV-M2 Specifications	
Nominal Pump Flow	20 GPM (76 LPM)
Nozzle Operating Pressure	4,000-PSI (275 BAR)
Driver / Pump	Dynaset HPW-320
Installation Environment	Submersible
Hydraulic Oil Flow Requirements	*See below.
Overall Unit Dimensions (L x W x H)	22" x 20" x 10" (55.8 cm x 50.8 cm x 25.4 cm)
Maximum Pressure Hose Length	300 LF (100 meters) of 3/4" (1.9 cm) diameter
Power Unit Weight (Dry)	140 LBS (63 KG)

*Hydraulic Power Unit must be capable of operating the water pressure pump at 55 HP. Consult us regarding the suitability of your existing Hydraulic Power Unit (HPU).

Figure 1.1 – CaviBlaster 2040-ROV-M2 Specifications

General Description:

The CaviBlaster 2040-ROV-M2 high-pressure waterpower unit allows the operator to use the water flow and pressure to generate cavitation at the end of the proprietary nozzle.

The CaviBlaster cleans the surface of any underwater structure using the energy released by the implosion of the bubbles during the cavitation process. When directed at the surface being cleaned, the energy released by the collapsing bubbles causes marine growth to be removed from the surface.

The system consists of a portable high-pressure pumping unit designed for submersible ROV use and a high-pressure cavitation lance (connected to ROV manipulator) with connecting high pressure hose.

The CaviBlaster 2040-ROV-M2 Power Unit is a complete “plug and play” system built on a supporting platform that allows quick deployment and/or installation of the unit. Water is supplied directly from the unit operating environment.

The unit is equipped with many features to maintain safety while operating at pressures of 4,000-PSI (275 BAR).

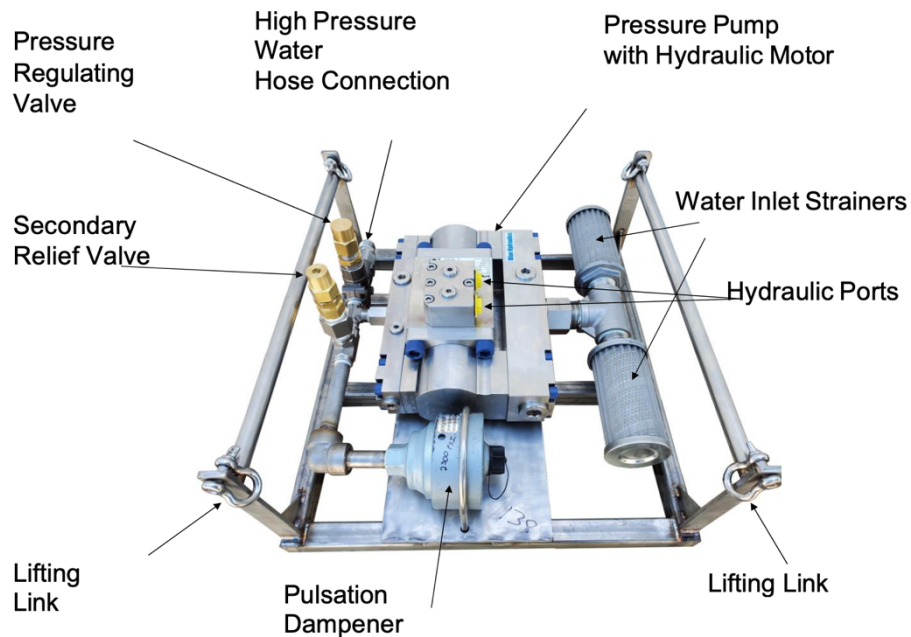

Figure 2.2 – CaviBlaster 2040-ROV-M2 General Features

Using this Manual:

Every attempt has been made to ensure that this documentation is complete and accurate at the time of publication. It is imperative; however, that anyone attempting to use this manual must have good comprehension of how this equipment operates. Further, this manual can in no way replace the common sense of an individual. If at any time this manual seems to contradict itself, or common sense, discontinue the procedure, re-read the section, and seek assistance from CaviDyne or other personnel familiar with the operation of this equipment.

Safety Information:

The CaviBlaster 2040-ROV-M2 Power Unit is an inherently powerful and potentially dangerous piece of equipment; however, with proper care and training it can be operated safely. The 2040-ROV-M2 must only be operated by personnel that have read and understand this manual. It is intended to reinforce and review safety techniques to prevent personal injuries and property damage.

Users must comply with all local, state, and national laws concerning high-pressure water jetting equipment as well as all underwater work regulations.

It is strongly recommended that this entire manual be reviewed in-depth before operating or servicing this equipment. Service work should only be performed by individuals who are proficient in using this equipment. Refer to the applicable section in this manual for the correct procedures prior to any installation, setup, or maintenance work.

NOTE: This unit does not have an oil pressure compensator. Dynaset unit consist of the stainless steel / corrosion resistant single body of the high-pressure water pump and hydraulic motor in it. For more information, please, see owner's manual in appendices below.

Personal Safety:

Operation of the CaviBlaster 2040-ROV-M2 underwater submersible ROV- mounted cleaning system must only be operated by personnel who have been trained in its use. Operation of the system without the proper training can result in property damage and damage to the CaviBlaster unit.



CAVIDYNE, LLC IS NOT RESPONSIBLE FOR DAMAGES OR INJURY RESULTING FROM FAILURE TO COMPLY WITH INSTRUCTIONS IN THIS MANUAL. PLEASE READ THE ENTIRE MANUAL CAREFULLY BEFORE USE.



IF MAINTENANCE OR REPAIR OF THE CAVIBLASTER GUN IS BEING CONDUCTED OUT OF THE WATER, REMEMBER THAT THE ZERO- THRUST GUN HAS FRONT AND REAR JETS. NEVER DIRECT THE JET STREAMS AT A PERSON OR ANIMAL, OR TOWARD POWER LINES OR OTHER HIGH VOLTAGE EQUIPMENT.



ENSURE THAT THERE IS A SAFE AREA TO WORK WHILE OPERATING THE CAVIBLASTER 2040-ROV-M2



SEEK IMMEDIATE MEDICAL ATTENTION IF THE OPERATOR SUFFERS AN INJURY AS THE RESULT OF CONTACT WITH THE HIGH-PRESSURE WATER STREAM. SERIOUS PERSONAL INJURY CAN RESULT FROM AN UNTREATED WATER INJECTION WOUND.

Personal Protective Equipment:

Always wear appropriate Personal Protective Equipment (PPE) when performing maintenance or calibration on this equipment.

Personnel operating or working in the vicinity of the Power Unit should wear appropriate hearing protection when operating the CaviBlaster during maintenance or calibration procedures. Personnel performing maintenance or calibration procedures on the CaviBlaster 2040-ROV-M2 system should always wear neoprene or heavy rubber gloves to provide protection to the hands and nails. The gloves will absorb most of the energy produced by bursting cavitation bubbles and prevent the cavitation bubbles from contacting the operators' hands. The gloves will also protect operators' hands from the initial shockwave when the lance is activated.



FAILURE TO WEAR APPROPRIATE PPE MAY RESULT IN PERSONAL INJURY.

Modification to the Equipment:

Do not make any unauthorized modifications or repairs to this equipment. Components used throughout this assembly were specifically designed or selected to safely meet the unique high-pressure requirements. Only replace parts with those recommended by or supplied by CaviDyne. Any unapproved modifications will void the equipment warranty. Unauthorized modification or part substitution can result in serious personal injury or property damage.



UNAUTHORIZED REPLACEMENT OF ANY PART MAY LEAD TO CATASTROPHIC EQUIPMENT FAILURE AND SERIOUS PERSONAL INJURY.

Installation:

The CaviBlaster 2040-ROV-M2 must be securely attached to the ROV using the vibration mounts supplied or other secure fastening mechanism.

Uncrating and Lifting:

Unpack the equipment and inspect for damage. If damage is found, immediately contact CaviDyne and the shipping company. **If there are missing parts/spare parts, contact freight carrier or insurance company.** If the unit will not be installed immediately, provide adequate indoor storage to protect against damage.

The CaviBlaster Power Unit should be lifted from underneath. Do not use components of the CaviBlaster to lift the entire unit.

DO NOT LIFT FROM ANY COMPONENT OF THIS UNIT

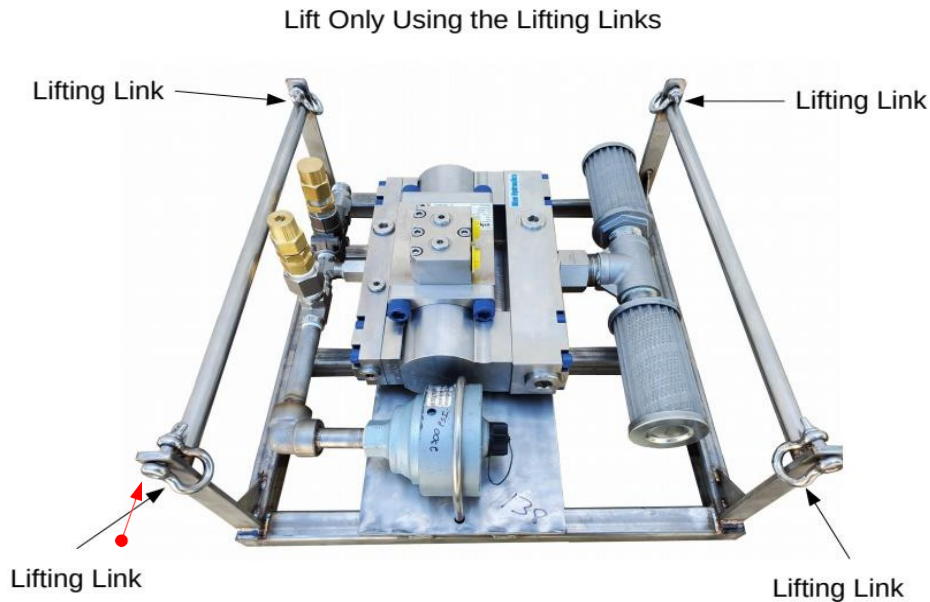
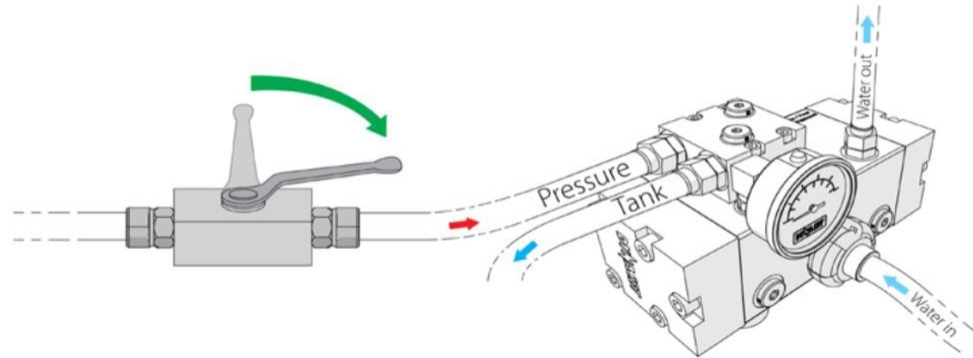

Figure 4.3 – Lifting Guidelines

Initial Set-Up:

Ensure that the unit is submerged in water.

When the HPU of base machine is running and hydraulic flow is available, the HPW pump can be started by opening the hydraulic control valve.



The CaviBlaster Lance attached to a pressure tool determines the flow rate and the pressure when operating parameters of hydraulic circuit meet the HPW pump's requirements.



MOTOR AND/OR PUMP FLUIDS HAVE BEEN REMOVED FOR SHIPMENT. CHECK FLUID LEVELS PRIOR TO STARTING. THERE CAN BE NO TRAPPED AIR IN THE UNIT FOR PROPER OPERATION.

Always use the cavitation lance that was calibrated with your CaviBlaster, it is very important for ensuring the optimal performance of your CaviBlaster 2040-ROV-M2



THE CAVIBLASTER 2040-ROV-M2 CAN BE USED WITH SEAWATER BUT MUST BE FLUSHED AND RINSED WITH FRESH WATER AFTER EVERY USE IN SEAWATER. FAILURE TO FLUSH AND RINSE THE POWER UNIT AFTER USE IN SEAWATER WILL RESULT IN INCREASED WEAR AND TEAR ON COMPONENTS AND CAN CAUSE THE PUMP VALVE(S) TO STICK IN THE OPEN POSITION. THIS WILL PREVENT THE SYSTEM FROM PRODUCING THE CORRECT OPERATING PRESSURE.

Operation:



This unit should be operated only by properly trained personnel who are familiar with the contents of this manual. Review the safety requirements found in Section 3 before operating.

Preparing the CaviBlaster for Operation:

The following checklist should be completed in advance, so that the unit is always ready for immediate use. This should be completed after each use.

1. Inspect the CaviBlaster Power Unit, hoses, JIC fittings and lance for any signs of damage.
2. Inspect the water inlet strainer to ensure that it is not clogged or damaged (See **Figure 2.1**). Clean if necessary.
3. Connect the CaviBlaster 1331-ROV to a Hydraulic Power Unit of the ROV.



INCORRECT OILS SHOULD NOT BE USED AS THEY MAY DAMAGE THE EQUIPMENT.

Startup of the CaviBlaster:

Before starting the CaviBlaster 2040-ROV-M2 unit, review all safety requirements found in **Section 3.0 SAFETY INFORMATION**. This equipment should only be operated by individuals who have read and understand the CaviBlaster Operation and Maintenance Manual.

1. Verify that the unit has been properly prepared for operation as described in **Section 4.0 INSTALLATION**.
2. Verify that the lance is properly connected to the CaviBlaster and the ROV.
3. Run the ROV hydraulic system to verify that the CaviBlaster hydraulic motor and pressure pump are functioning correctly.

Normal Operation:

Normal operation of the CaviBlaster system is defined as user control of water flow via the lance. In the absence of a diver, control of the Power Unit is accomplished by the ROV manipulator. Should a problem develop with the control valve, discontinue using the CaviBlaster until fixed.



REVIEW THE SAFETY REQUIREMENTS FOR PPE AND SAFE OPERATION BEFORE PROCEEDING.

1. The ROV hydraulic system needs to be operating at a capacity that matches the water pressure pump requirements for the CaviBlaster 2040-ROV-M2 to function correctly. Dynaset recommend is to achieve a proper operation hydraulic system must deliver 33 GPM @ 3,600-PSI. Unlike gasoline or diesel engines, a hydraulic motor will run as fast as the oil supply it receives, which means that the hydraulic oil supply must be adjusted to match the water pressure pump requirements. Consult with CaviDyne to determine if your high-pressure oil supply unit is suitable for use with the CaviBlaster 2040- ROV-M2.
2. Activate the cleaning cavitation stream by turning "ON" the hydraulic Power Unit.



ALTHOUGH THE CAVIBLASTER SYSTEM IS SAFE TO USE WHEN SUBMERGED IN WATER, THE SYSTEM GENERATES A HIGH-PRESSURE (UP TO 4,000-PSI [275 BAR]) WATER STREAM, WHICH CAN CAUSE INJURY WHEN THE LANCE IS OUT OF THE WATER. ALWAYS KEEP THE LANCE SUBMERGED WHEN THE PRESSURE PUMP IS ENGAGED.

Adjusting the CaviBlaster for Maximum Performance:

The pressure at the nozzle of the lance must be maintained within certain limits to achieve cavitation and for best performance results. If using a calibration pressure gauge situated between the pressure hose and the CaviBlaster lance, the water pressure should be 4,000-PSI (275 BAR) with the lance submerged and the hydraulic Power Unit operating. For best results, repeat this calibration procedure if cleaning performance degrades, or every 3 months at a maximum.



A CALIBRATION GAUGE IS RECOMMENDED WITH EVERY UNIT. CONNECT BETWEEN THE END OF THE HOSE AND THE LANCE.

To Calibrate the Pressure at the Zero-Thrust Gun, Follow the Procedure Below:

1. Stop the hydraulic Power Unit to discharge any residual pressure in the hose lines.
2. Disconnect the lance from the main hose line.
3. Attach the calibration gauge between the main hose line and the lance and tighten it (See **Figure 5.1**).
4. Submerge the lance. Because of the danger of the operator coming in contact the water stream from the cavitating nozzle, CaviDyne does **NOT** recommend calibrating the lance out of the water. Use extra care to avoid the water stream if doing so.
5. Ensure that the cavitation nozzle is pointed away from the diver's or operator's hands, arms and body.
6. Start the hydraulic Power Unit.
7. Hold the lance tight and observe the calibration gauge (See **Figure 5.1**).
8. Turn the knob on top of the pressure regulating valve until pressure reads 4,000-PSI (275 BAR) on the calibration gauge. Turning the knob clockwise will increase the pressure and turning it counterclockwise will decrease the pressure.



DO NOT ADJUST THE PRESSURE AT THE LANCE TO MORE THAN 4,000-PSI (275 BAR). HIGHER PRESSURE WILL NOT IMPROVE PERFORMANCE.



HOSE LINES ARE RATED FOR 3,190-PSI (220 BAR). PRESSURES ABOVE 4,000-PSI (275 BAR) COULD RESULT IN PUMP AND / OR HOSE FAILURE.

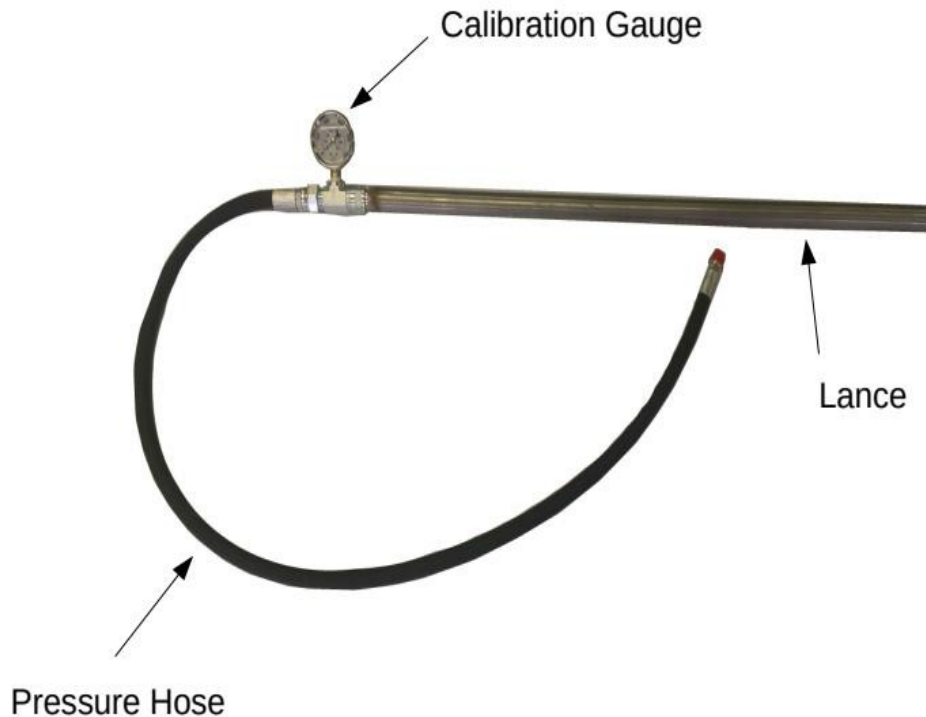

Figure 5.1 – Lance Pressure Calibration

Recommendations for Effective Results:

When the ROV operator is ready to commence cleaning operations, verify that the lance is securely attached to the manipulator.

Once the hydraulic Power Unit is operational and the water jet stream is flowing from the lance, the ROV operator must find the most effective distance between the lance nozzle and the surface being cleaned (See **Figure 5.2**).

1. Engage the ROV's hydraulic Power Unit to activate the CaviBlaster unit.
2. The most efficient operating technique is to hold the nozzle 2-5 inches (5-12 cm) away from the surface to be cleaned and at a 25-to-45-degree angle to the surface being cleaned (See **Figure 5.2**). The ROV operator needs to observe the shape of the cavitating jet cone. At greater depths, the higher ambient pressure will cause the jet cone to be shorter. The widest zone of the cone is the most efficient part of the cavitating jet. Placing the nozzle closer than 2 inches (5 cm) from the surface being cleaned will not allow for efficient cavitation performance and will degrade the cleaning capability of the CaviBlaster system.
3. Follow all safety regulations that may be applicable to the work being performed.

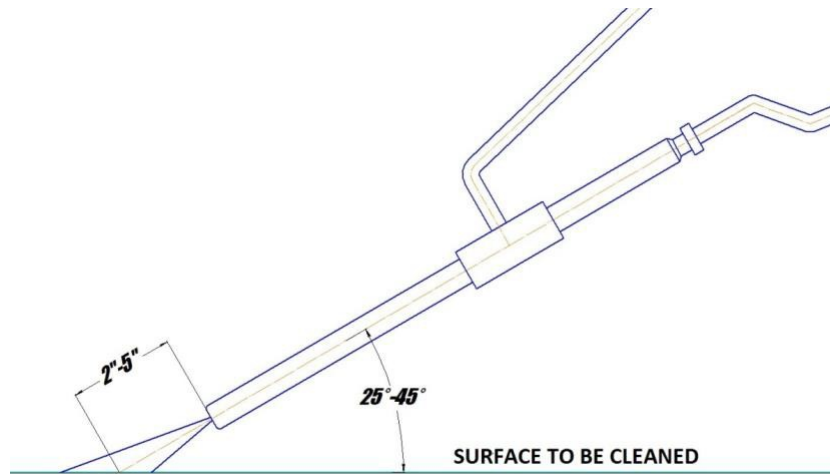

Figure 5.2 – Lance Position for Best Cleaning Results

Shutting Down the CaviBlaster 2040-ROV-M2:

1. Shut down the ROV hydraulic Power Unit, this will turn off the pressure pump and relieve pressure in the system.
2. It is now safe to remove the lance from the water.
3. Flush the system and rinse the Power Unit with fresh water at the end of the day or work shift.

Maintenance:

Maintenance on this unit should be restricted to authorized personal that have been properly trained. Review this manual, especially **Section 3.0 SAFETY INFORMATION**, prior to performing any service on this equipment.



FAILURE TO FLUSH AND RINSE THE UNIT WILL RESULT IN PREMATURE WEAR AND TEAR ON THE COMPONENTS AND DECREASED SERVICE LIFE.



EQUIPMENT MUST BE “OFF” AND PRESSURE RELEASED FROM ALL HOSES PRIOR TO ANY SERVICE WORK.



ONLY REPLACE PARTS WITH THOSE SUPPLIED OR APPROVED BY CAVIDYNE, LLC. USE OF ANY OTHER PARTS MAY LEAD TO EQUIPMENT FAILURE AND SEVERE PERSONAL INJURY



THE CAVIBLASTER 2040-ROV-M2 MUST BE FLUSHED AND RINSED AFTER EACH USE IN SEA WATER.

Basic Preventive Maintenance Recommendations:

Task	Before and After Every Use	Every 6 Months or 125 Hours*	Every 12 Months or 250 Hours*	Every 12 Months or 500 Hours*	Every 1,000 Hours
Check water inlet strainer cartridge(s) and clean if necessary	X				
Inspect hoses for wear or damage ¹	X				
Check pump valves and seals for wear & change if necessary					X

* Whichever occurs first.

1. If any hose damage found, replace hose immediately.
2. If any damage to the strainers, replace immediately.

Pump Service:

The high-pressure water pump requires minimal maintenance. The pump oil should be checked on a regular basis.

Inspection / Cleaning of Water Inlet Strainer:

The water inlet strainer should be inspected and cleaned after each use of the CaviBlaster 2040-ROV-M2.

Troubleshooting:

WATER IN CRANK CASE

- Check the pump seals for damage
- Check the plungers for cracks
- Check the plunger rod O-ring for damage

LANCE IS NOT CLEANING PROPERLY

- Remove the CaviBlaster unit from the water and mount the lance securely in a vice or test stand. Make sure the lance is pointed away from any personnel and any electrical systems or components in the area. The water jet from the lance can travel 40-50 feet (12-15 meters).
- Connect the Dynaset pump to a hydraulic Power Unit and start the hydraulic Power Unit. Verify that the hydraulic Power Unit is delivering the correct flow and pressure (33 GPM @ 3,600-PSI) required to operate the water pressure pump.
- If water is leaking out of the hose, fittings or connections replace the damaged component and securely tighten all connections.
- If water is leaking from the lance body, contact CaviDyne for further instructions.
- Check lance and nozzle for foreign particles.
- Visual inspection:
 - Insert a small wire into nozzle orifices to check for obstruction(s) and “backflush” with compressed air or pressurized water.

Replacement Parts:

CaviBlaster 2040-ROV-M2 Power Unit Replacement Parts			
Recommended Order Qty.:	Qty. Per Assembly:	Part Description:	Part Number:
2	2	Water Inlet Strainer	CASS-20-1-100-316
1	1	Pump Seal Kit	
1	1	Pump Valve Kit	
1	1	Pressure Regulator (Optional)	
1	1	Regulating Unloader	UB402
1	1	Safety Relieve Valve	CAT 9941

