



CAVIBLASTERTM

CAVIDYNE LLC

5077 Fruitville Rd., Suite

109-157 Sarasota, FL 34232

Phone: (352) 275-5319

Operation & Maintenance Manual



Model 2828-D



CaviDyne LLC is not responsible for damages or injuries resulting from a failure to comply with instructions in this manual. Please read entire manual carefully before use.



The CaviBlaster 2828 must only be operated and maintained by trained personnel.



This equipment generates high pressure water and is intended for underwater use only. **Serious personal injury or death may result from improper use.**



Commercial Diver's gear should be used to operate the CaviBlaster system.

TABLE OF CONTENTS

1.0 UNIT SPECIFICATIONS	5
2.0 GENERAL DESCRIPTION	6
2.1 Using this Manual	10
2.2 Conventions.....	10
2.3 Scope	10
2.4 Terms and Abbreviations.....	10
3.0 SAFETY INFORMATION	11
3.1 Personal Safety	11
3.2 Personal Protective Equipment	12
3.3 Modification to the Equipment	13
4.0 INSTALLATION	14
4.1 Uncrating and Lifting.....	14
4.2 Installation Location	15
4.3 Initial Set Up	16
4.3.1 Connecting the Battery Terminals.....	16
4.3.2 Connecting the Water Source	18
5.0 OPERATION	21
5.1 Preparing the CaviBlaster for Operation.....	21
5.2 Startup of the CaviBlaster.....	22
5.3 Normal Operation	23
5.4. Adjusting the CaviBlaster for maximum performance	25
5.5. Recommendations for Effective Results.....	28
6.0 MAINTENANCE	31
6.1 Basic Preventive Maintenance Recommendations	32
6.2 Diesel Engine Service	33
6.3 Pump Service	33
6.4 Inspection/Cleaning of Water Inlet Strainer and Filter	33
6.5 Inspection / Maintenance of the belt drive system.....	35
6.6 Inspection / Maintenance of the Zero-Thrust Guns	37
8.0 TROUBLESHOOTING	39
9.0 REPLACEMENT PARTS	41
APPENDIX - COMPONENT LITERATURE	42

LIST OF FIGURES & TABLES

- Figure 1.1 – CaviBlaster 2828 Specifications*5
*Figure 2.1 – CaviBlaster 2828 Cleaning Options***Error! Bookmark not defined.**
*Figure 2.2 – CaviBlaster 2828 General Features*8
*Figure 2.3 – CaviBlaster 2828 Control Panel*9
*Figure 4.1 – Lifting Guidelines*14
*Figure 4.2 – Installation Guidelines*15
*Figure 4.3 – Reconnecting the Battery Terminals*17
*Figure 4.4 – Gravity Feeding Source*18
*Figure 5.1 – Engine Emergency Shut-Down and Throttle Control*25
*Figure 5.2 – Gun Pressure Calibration*27
*Figure 5.3 – Gun Position for Best Results*28
*Figure 6.1 – Inspection / Cleaning Water Strainer/Filter*33
*Figure 6.2 – Inspection / Belt tension.*34
*Figure 6.3 – Inspection / Belt tension.*35
*Figure 6.3 – Zero-Thrust Gun*36

This space intentionally left blank

(EOS)

1.0 UNIT SPECIFICATIONS

The CaviBlaster 2828 power unit consists of a 51HP (38 kW) Kubota V2403-Turbo diesel power-pack and a UDOR VX-100/200 positive displacement triplex plunger pump. Detailed performance and specifications are listed below:

CaviBlaster 2828 Specifications	
Nominal Pump Flow	28 GPM (106 LPM)
Operating Pressure	2800 PSI (193 BAR)
Engine	51 HP (38kW) Diesel Powered (Kubota V2403-Turbo)
Installation Environment	Outdoor enclosed or exposed <i>See Section 4 for installation requirements</i>
Fuel Requirements	Diesel fuel (ASTM Grade No. 1-D or 2-D)
Fuel Tank Capacity	50 Gallons (190 Liters)
Water Inlet Pressure Limits	0-PSI (Atmospheric Pressure) to 70-PSI Maximum (0 BAR to 4.8 BAR) <i>See Section 4 for further requirements</i>
Overall Unit Dimensions (L x W x H)	51" x 51" x 63" (130 cm x 130 cm x 155 cm)
Maximum Pressure Hose Length	600 LF (200 meters) of 3/4" diameter
Power Unit Weight (Dry)	1600 LBS (726 KG)

Figure 1.1 – CaviBlaster 2828 Specifications

(EOS)

2.0 GENERAL DESCRIPTION

The CaviBlaster 2828 high-pressure water power unit allows the operator to use the water flow and pressure to generate cavitation at the end of the proprietary nozzle.

The CaviBlaster cleans the surface of any underwater structure using the energy released by the implosion of the bubbles during the cavitation process. When directed at the surface being cleaned, the energy released by the collapsing bubbles causes marine growth to be removed from the surface.

The system consists of a diesel-powered high-pressure pumping unit with connecting high pressure hose which is capable of operating one 2828 Zero-Thrust Gun (28 gpm, 106 LPM, flow); two 1428 Zero-Thrust Guns (14 gpm, 53 LPM, flow per gun); or one DoubleDome (28 gpm, 106 LPM, flow total) with four rotating nozzles. It is important to use only the guns/dome specified in order to maintain flow rates, pressure and cleaning capability. When operating with the 2828 Zero-Thrust Gun, closing the trigger valve causes water to go through the valve in the handle of the gun. When operating with two 1428 Zero-Thrust guns, closing the trigger valve of one gun allow the other gun to function normally while the flow for the closed gun goes to bypass at the unit. Closing both trigger valves causes the power unit to go into full bypass mode, unloading the engine and the pump. The DoubleDome is also equipped with a trigger gun when used by a diver, closing the trigger valve causes the power unit to go into bypass mode, unloading the engine and the pump. DoubleDomes used on ROVs do not have a trigger valve and water flow is controlled by the CaviBlaster unit.

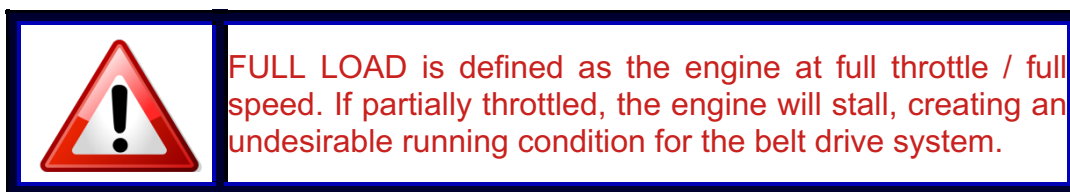

The CaviBlaster 2828 power unit is a complete “plug and play” system built into a self-supporting frame that allows quick deployment and/or installation of the unit. Water can be supplied from either a pressurized source; directly from the natural source via an electric booster pump supplied with the power unit; or from a gravity storage feed tank.

The unit is equipped with many features to maintain operator safety while operating at pressures of 2,800-psi (193 BAR).



2828 Zero-Thrust **Dump** Gun
Flow Capacity 28 GPM (106 LPM)



1428 Zero-Thrust Gun
Flow Capacity 14 GPM (53 LPM) Per Gun



DoubleDome
Flow Rate 28 GPM (106 LPM)

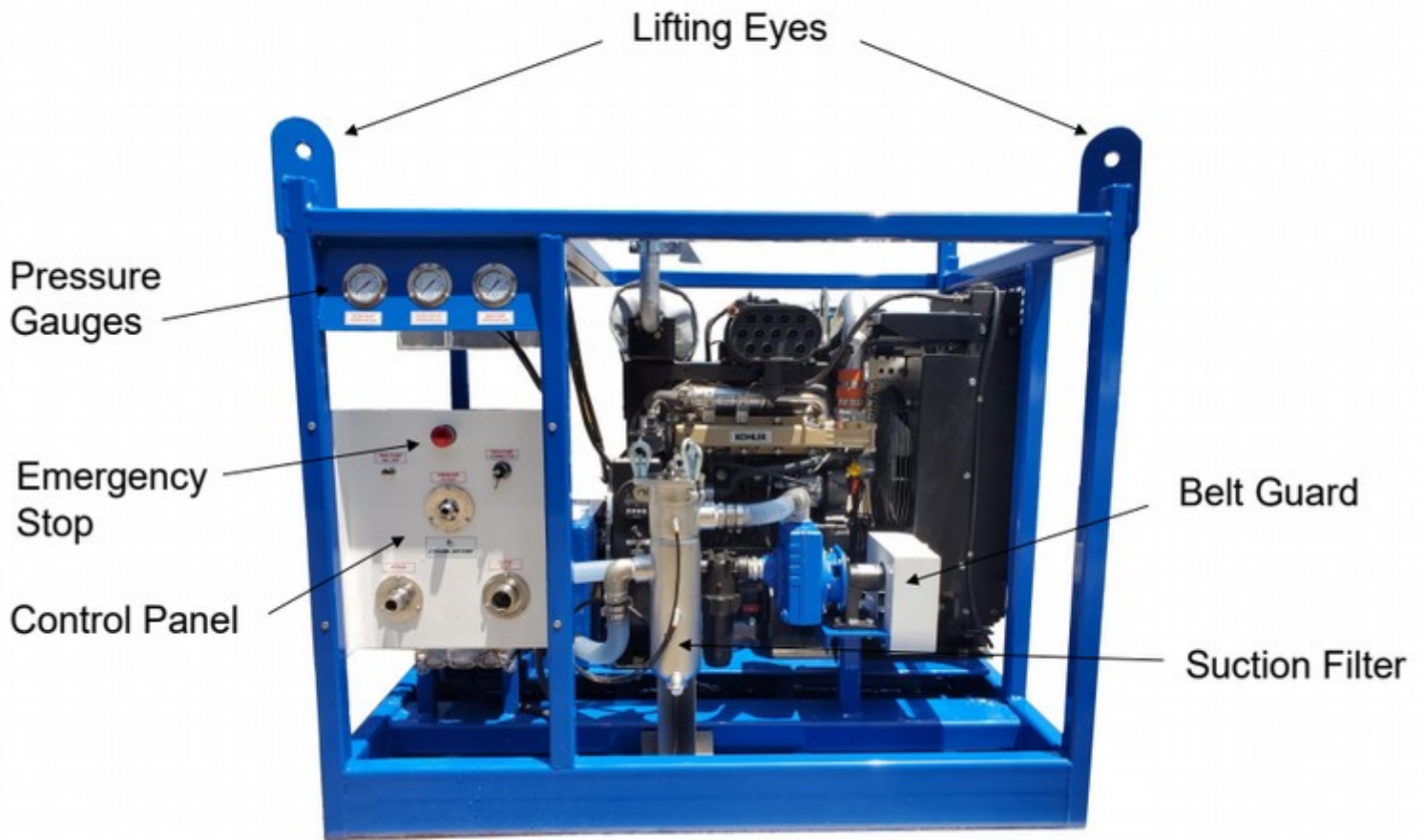

Figure 2.2 – CaviBlaster 2828 General Features

NOTE: New generation Diesel engines with emission control requirements at a level “Tier 4F” in USA and “Stage V” in EU governed by computer systems with better electric control and higher redundancy of safety features DO NOT require an Emergency Stop Button.

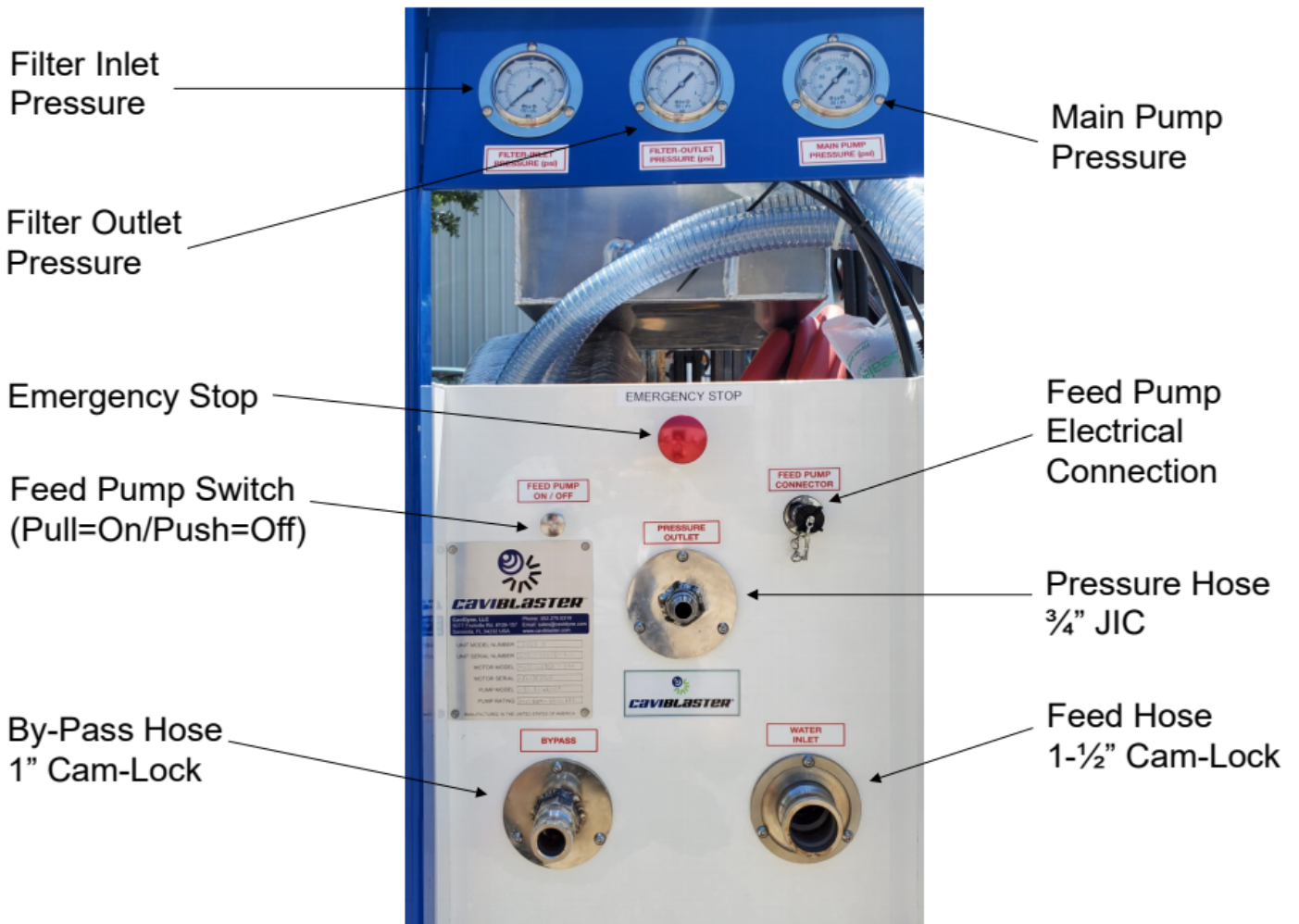

Figure 2.3 – CaviBlaster 2828 Control Panel

NOTE: New generation Diesel engines with emission control requirements at a level “Tier 4F” in USA and “Stage V” in EU governed by computer systems with better electric control and higher redundancy of safety features DO NOT require an Emergency Stop Button.

2.1 Using this Manual

Every attempt has been made to ensure that this documentation is complete and accurate at the time of publication. It is imperative; however, that anyone attempting to use this manual must have good comprehension of how this equipment operates. Further, this manual can in no way replace the common sense of an individual. If at any time this manual seems to contradict itself, or common sense, discontinue the procedure, re-read the section, and seek assistance from CaviDyne™ or other personnel familiar with the operation of this equipment.

2.2 Conventions

The first time a component is mentioned, it is typically followed by a figure reference; e.g., Ignition key (See Figure 2.2.) Figure numbers and section numbers are always coincident.

When other sections are referenced the *SECTION NAME* will appear in italic caps. The electronic version allows users to click on the section name or figure reference to jump to that section. The words “**This space intentionally left blank**” will appear where there is more than 3 inches of white space.

(EOS) will appear above the page number on the last page of each section.

2.3 Scope

This manual covers installation, operation, and maintenance of the CaviBlaster 2828. It is essential that personnel who will operate and/or service this equipment familiarize themselves with this manual. Standard components, such as the unit engine and pump, are covered by the manufacturer’s literature found in the Appendix.

2.4 Terms and Abbreviations

CCW	Counterclockwise
CW	Clockwise
EOS	End of Section
GPM	Gallons Per Minute
HP	Horsepower
LPM	Liters Per Minute
PPE	Personal Protective Equipment
PSI	Pounds Per Square Inch (without suffix, assumed to be gauge pressure).

3.0 SAFETY INFORMATION

The CaviBlaster 2828 power unit is an inherently powerful and potentially dangerous piece of equipment; however, with proper care and training it can be operated safely. The CaviBlaster 2828 must only be operated by personnel that have read and understand this manual. It is intended to reinforce and review safety techniques to prevent personal injuries and property damage.

Users must comply with all local, state, and national laws concerning high-pressure water jetting equipment as well as all underwater work regulations.

It is strongly recommended that this entire manual be reviewed in-depth before operating or servicing this equipment. Service work should only be performed by individuals who are proficient in using this equipment. Refer to the applicable section in this manual for the correct procedures prior to any installation, setup, or maintenance work.

3.1 Personal Safety

Operation of the CaviBlaster 2828 underwater cleaning system must only be attempted by commercial divers or other personnel who have been trained in its use. Appropriate protective equipment should always be worn. Operation of the system without the proper equipment and training can result in personal injury. DoubleDome can be operated by a diver or as an ROV attachment. When using as an ROV attachment, consult ROV safety requirements prior to using.



CaviDyne LLC is not responsible for damages resulting from a failure to comply with instructions in this manual. Please read carefully before use.



If maintenance or repair of the CaviBlaster gun is being conducted out of the water, remember that the zero-thrust guns have front and rear jets. Never direct the jet streams at a person or animal. Never direct the jet streams toward power lines or other high voltage equipment.



Ensure that there is a safe area to work while operating the CaviBlaster 2828.



Seek immediate medical attention if the operator suffers an injury as the result of contact with the high-pressure water stream. **Serious personal injury can result from an untreated water injection wound.**

3.2 Personal Protective Equipment

Always wear appropriate Personal Protective Equipment (PPE) when operating this equipment.

Personnel operating or working in the vicinity of the power unit should wear appropriate hearing protection when the CaviBlaster system is in use. If the diver is not wearing a diving helmet, hearing protection is recommended. CaviDyne™ suggest wearing vented earplugs, such as “Doc’s Pro-plugs”, for diver hearing protection.

The operators of the CaviBlaster system should always wear neoprene or heavy rubber gloves to provide protection to the hands and, in particular, to the nails. The gloves will absorb most of the energy produced by bursting cavitation bubbles and prevent the cavitation bubbles from contacting the operators’ hands. The gloves will also protect operators’ hands from the initial shockwave when the gun is activated.



Failure to wear appropriate PPE may result in personal injury.

3.3 Modification to the Equipment

Do not make any unauthorized modifications or repairs to this equipment. Components used throughout this assembly were specifically designed or selected to safely meet the unique high-pressure requirements. Only replace parts with those recommended by or supplied by CaviDyne. Any unapproved modifications will void the equipment warranty. Unauthorized modification or part substitution can result in serious personal injury or property damage.



This space intentionally left blank

(EOS)

Page 13/41

For more information please email sales@cavidyne.com or call 1-(352)275-5319

4.0 INSTALLATION

The CaviBlaster 2828 must be installed in accordance with the requirements outlined below.

4.1 Uncrating and Lifting

Unpack the equipment and inspect for damage. If damage is found, immediately contact CaviDyne™ and the shipping company. *If the unit will not be installed immediately, provide adequate indoor storage to protect against damage.*

The CaviBlaster power unit should be lifted from underneath the frame using the forklift channels or by using the lifting eyes provided on top of the frame. Verify that lifting equipment is rated for the weight listed in Section 1.0 *UNIT SPECIFICATIONS* and that the unit is stable before lifting.

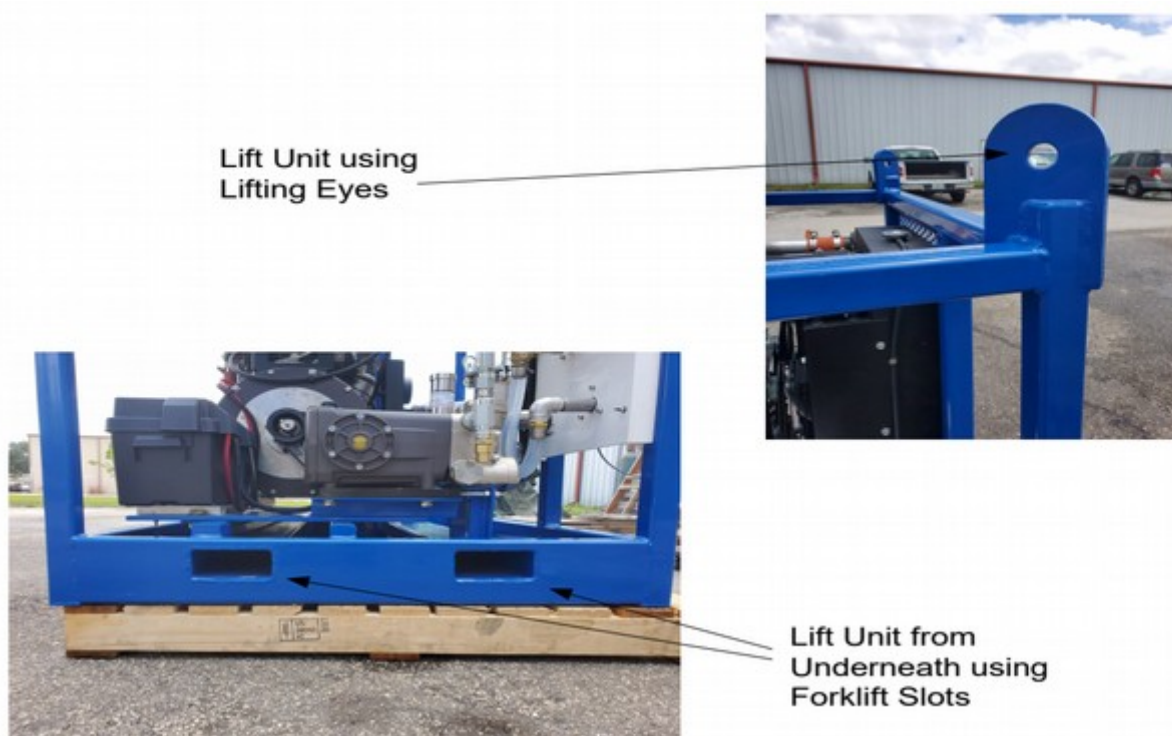

Figure 4.2 – Lifting Guidelines

4.2 Installation Location

For maximum flexibility the CaviBlaster power unit should be installed in an area where it is capable of reaching both its water source and anticipated cleaning targets within acceptable hose lengths. The CaviBlaster power unit can be installed in an enclosed* or open environment.

*** Enclosed installations will require provisions for adequate engine cooling air flow and for venting of engine exhaust.**

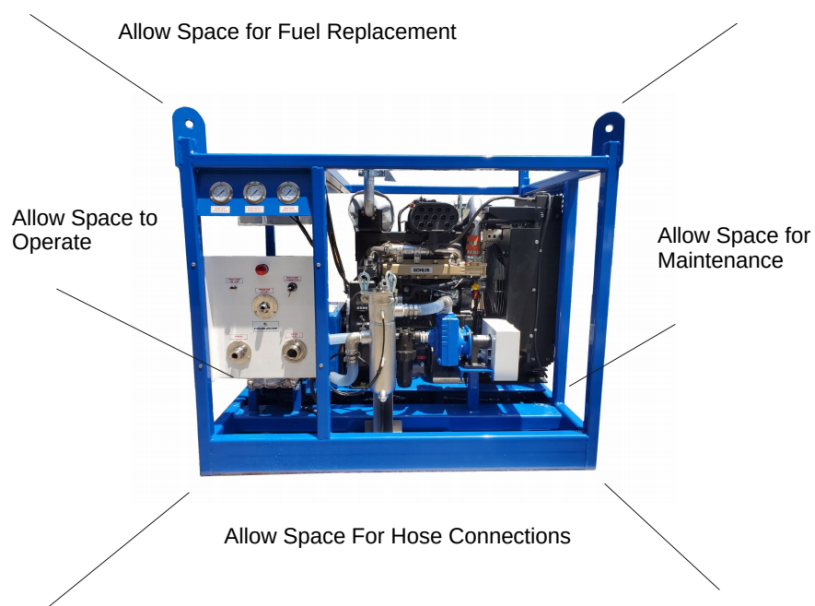

Figure 4.3 – Installation Guidelines

Installation location must be a level surface able to safely support the unit weight listed in Section 1.0 *UNIT SPECIFICATIONS*. Orient unit to allow unrestricted access to the hose connection plate and control panel, located on the front of the unit. Allow a minimum of three feet behind the unit and access from above to conduct service and repair work. Take note of frequently serviced areas such as the engine and fuel tank.

4.3 Initial Set Up

After first receiving the CaviBlaster power unit, the following must be checked and completed:

- 1) Connect the battery (See Section 4.3.1).
- 2) Add engine oil (See Engine Manual located in the *APPENDIX*).
- 3) Add engine coolant (See Engine Manual located in the *APPENDIX*).
- 4) Add pump oil (See Pump Manual located in the *APPENDIX*).
- 5) Connect the feed or suction (clear) hose (See Section 4.3.2 and Figure 2.3).
- 6) Connect the bypass (red) hose (See Figure 2.3).
- 7) Connect the pressure hose (See Figure 2.3).
- 8) Connect the electric feed pump (See Section 4.3.2 and Figure 2.3).
- 9) Fill the fuel tank using diesel fuel ASTM Grade 1-D or 2-D, or EN 590. (See fuel requirements in Engine Manual located in the *APPENDIX*).



4.3.1 Connecting the Battery Terminals

For shipping purposes, the battery terminals have been disconnected. To reconnect the battery, reference Figure 4.3 and the procedure below:

1. Remove the engine ignition key. (See Figure 5.1)
2. Open the battery box by loosening the strap and removing the cover.
3. Connect the battery terminals as follows: (See Figure 4.3)

RED to positive terminal

BLACK to negative terminal

4. Tighten the terminal screws securely.
5. Replace the battery cover and secure with strap.

1-Main Battery Location



2-Remove Protection Cover



3-Locate Cables

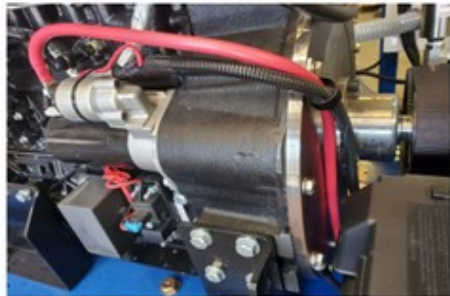

Black=Negative / Red=Positive

4-Connect Terminals



Positive
RED

Negative
BLACK

Figure 4.3 – Reconnecting the Battery Terminals

4.3.2 Connecting the Water Source

The CaviBlaster power unit can be used with seawater or fresh water. It must be flushed with fresh water for 1-2 minutes after each use in seawater to ensure long service life.



The CaviBlaster 2828 must be flushed and rinsed with fresh water after every use in seawater.



Failure to flush and rinse the power unit after use in seawater will result in increased wear and tear on components and in decreased service life.



Failure to flush and rinse the unit can cause the pump valve(s) to stick in the open position. This will prevent the system from producing the correct operating pressure.

The feed water inlet connection is located on the control panel (See Figure 2.3). A 12V electric bilge water pump is supplied to provide positive inlet water pressure to the main pressure pump. Two water supply conditions are acceptable for the CaviBlaster power unit.

- Forced inlet water condition using the supplied electric water pump or an outside water source capable of supplying at least 28 GPM (106 LPM) at a **maximum pressure of 70-PSI (4.8 BAR)**.
- Gravity feeding water source (See Figure 4.4). In this case the electric pump is not required. Use a hose with a diameter of at least 1-1/2" to connect the water tank to the power unit

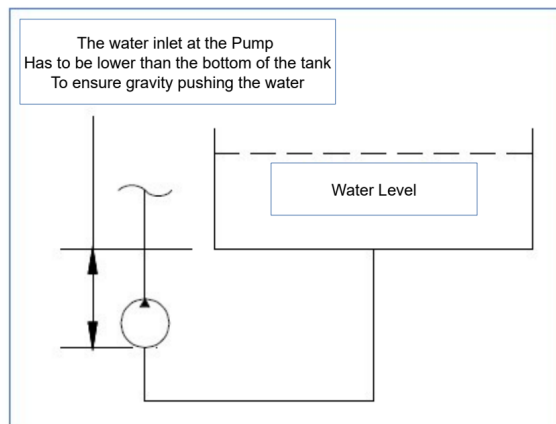

Figure 4.4 – Gravity Feeding Source

To use the feed pump supplied with the system:

- Turn the engine ignition key to OFF (See Figure 2.3).
- Connect the cam-lock socket on the 1-1/2" clear PVC feed hose to the water inlet connection on the control panel (See Figure 2.3).
- Connect the electrical plug on the feed pump power cable to the matching receptacle on the control panel (See Figure 2.3).
- Submerge the feed pump into the water source, one or two feet.
- Pull the feed pump ON/OFF switch out to activate the feed pump (See Figure 2.3).
- Run the feed pump until water begins to flow from the pressure hose connection on the control panel.
- Turn off the feed pump.
- Release the Emergency Engine Shut-Down button
- It is important not to operate the feed pump for long periods of time without the engine operating as this will discharge the battery.

To use force feed from an alternate source:

- Turn the engine ignition key to OFF (See Figure 2.3).
- When feeding the CaviBlaster with an alternate water source, **the source must supply water at a volume of greater than 28 GPM (106 LPM) at a maximum pressure of 70-psi (4.8 BAR).**
- Connect a 1-1/2" cam-lock socket on the water supply hose to the water inlet connection on the control panel (See Figure 2.3).
- Turn on the alternate water source until water begins to flow from the pressure hose connection on the control panel. (See Figure 2.3).
- Turn off the alternate water source.



Ensure that the feed hose is connected to the inlet connection and the water supply is on prior to starting the pressure pump. Failure to supply water to the pressure pump will cause damage to the pressure pump.

To use gravity feed:

- Locate the water supply tank so that the bottom of the tank is higher than the water inlet on the control panel (See Figures 2.3 and 4.4).
- Turn the engine ignition key to OFF (See Figure 2.3).
- Connect a minimum 1-1/2" hose to the water inlet 1-1/2" cam-lock plug.

- Connect the other end of the hose to the water supply tank.
- Make sure the lowest point in the hose line is the connection with the power unit.
- Turn on the gravity feed water source until water begins to flow from the pressure hose connection on the control panel. (See Figure 2.3).
- Turn off the gravity feed water source.
- It is essential that adequate water is supplied to the water supply tank to maintain the water level several inches above the bottom of the tank. Failure to maintain an adequate water level in the supply tank could starve the pressure pump of water causing damage to the seals or other components of the pressure pump.

Ensure that the water source can reliably deliver the maximum pressure pump flow of 28 GPM (106 LPM). A minimum flow of 35 GPM (133 LPM) is recommended to ensure that the pressure pump is not starved of water. If connecting to a tank, locate the bottom of the tank above the water inlet connection on the power unit to ensure a flooded suction line (See Figure 4.4).

(EOS)

5.0 OPERATION

The CaviBlaster 2828 should be operated by two (2) properly trained individuals. One, the diver (or ROV operator), operates the zero-thrust gun(s), while the other operates the power unit. Both operators should be in audio or visual communication with each other.



The CaviBlaster 2828 should only be operated by properly trained personnel who are familiar with the contents of the manual. Review the safety requirements found in Section 3 before operating.

5.1 Preparing the CaviBlaster for Operation

The following checklist should be completed in advance, so that the unit is always ready for immediate use. This should be completed after each use.

- 1) Inspect the CaviBlaster power unit, hoses, JIC fittings and gun for any signs of damage
- 2) Inspect the inline strainer and filter cartridge to ensure they are not clogged (See Figure 6.1). Clean strainer or replace filter cartridge if necessary.
- 3) Check for proper engine oil level (See engine Owner's Manual found in the *Appendix*). Add lubricating oil (SAE 10W40) if necessary.
- 4) Check for proper pressure pump oil level (See pump Owner's Manual found in the *Appendix*). Add hydraulic oil (SAE 30 non-detergent) if necessary.
- 5) Check fuel tank (See Figure 2.1) for proper diesel fuel level. Add diesel fuel (ASTM Grade No. 1-D or 2-D, or EN 590) if necessary.



Incorrect fuels should not be used as they may prove hazardous.

5.2 Startup of the CaviBlaster

Before starting the CaviBlaster 2828 power unit, review all safety requirements found in Section 3.0 *SAFETY INFORMATION*. This equipment should only be operated by individuals who have read and understand the CaviBlaster Operation and Maintenance Manual.

- 1) Verify that the unit has been properly prepared for operation as described in Section 4.
- 2) Verify that the gun(s) or DoubleDome are properly connected and the gun mechanical trigger is released.
- 3) Verify that the throttle cable is fully depressed. (Full throttle - See Figure 5.1).
- 4) **Apply appropriate hearing protection prior to starting engine.**
- 5) Insert the key into the ignition switch on the ignition panel (See Figure 2.3). Turn the key clockwise to start the engine. If the engine does not start within 10 seconds, return the key to the "OFF" position and wait at least 30 seconds before operating the starter again. Once the engine starts, release the key, allowing it to return to the "ON" or running position and ad.
- 6) Run the engine at idle speed for a minimum of 20 seconds (20") at operating temperatures above 41°F (5°C). For lower operating temperatures, run engine at idle speed for a minimum of one minute (1'). **DO NOT ALLOW THE ENGINE SPEED TO EXCEED 1200 RPM. EXCEDING 1200 RPM WILL ENGAGE THE PRESSURE PUMP AND CREATE AN UNSAFE CONDITION FOR PERSONEL IN THE VICINITY OF THE UNIT.**





In operation, the engine must be run at full throttle/full speed. If partially throttled, the engine will stall, creating an undesirable running condition for the belt drive system.

5.3 Normal Operation

Normal operation of the CaviBlaster system is defined as user control of water flow via the gun trigger. Control of the power unit from the gun trigger is accomplished by a mechanical shut-off valve in the gun. Should a problem develop with the control valve, discontinue using the CaviBlaster until fixed.

The CaviBlaster 2828 power unit is designed to operate at full throttle. Less than full throttle will result in malfunction of the belt drive system and less than optimum cleaning performance.



Review the safety requirements for PPE and safe operation before proceeding.

- 1) Verify that the gun(s) or DoubleDome are properly connected and the gun mechanical trigger is released and the DoubleDome ball valve is closed.
- 2) When the diver/ROV operator is ready to commence cleaning operations, ensure that the gun/DoubleDome is submerged in water. **Ensure that the power unit operator and other persons working in the vicinity of the power unit wear appropriate hearing protection when the engine is running.** If the diver is not wearing a helmet, hearing protection is recommended. CaviDyne™ suggests vented earplugs such as “Doc’s Proplugs” for diver hearing protection.
- 3) **Wear neoprene or rubber gloves to protect the hands and follow all safety regulations that may be applicable to the work being performed.**
- 4) The gun trigger should be in open or “ON” position (See Figure 5.3) when throttling up the engine to engage the pressure pump. This will prevent the pressure pump from being in a loaded condition which will cause damage to the belts while they are engaging the pressure pump. Open the gun

trigger on the DoubleDome and submerge the DoubleDome before starting the engine.

- 5) Start up the power unit as described in section 5.2.
- 6) Throttle the engine up by completely pulling the black throttle cable knob all the way out and twisting the knob to lock it (See Figure 5.1).
- 7) Activate the cleaning cavitation stream by squeezing the trigger to the open or "ON" position (See Figure 5.3). Release trigger to stop the water flow and direct to dump or bypass. Open the ball valve on the DoubleDome to start the nozzles rotating, close the ball valve to stop the nozzle rotation. Engine must be at full throttle for nozzles to function.
- 8) If the diver operating the unit must be replaced or the cleaning operation must be interrupted or terminated, disengage the pressure pump by pushing the throttle lever in to the idle position and turning the ignition key to the "OFF" position. (See Figure 5.1) **Then release the water pressure in the hose(s) by squeezing the gun trigger to the open or "ON" position (See Figure 5.3) while under water.** Revert back to step 3 of the operating instructions when the diver or replacement is ready to continue cleaning.
- 9) After the engine has shut down, close the ball valve on the DoubleDome to ensure that the nozzles are not rotating.



Although the CaviBlaster system is safe to use when submerged in water, the system generates a high-pressure (up to 2,800-psi [193 BAR]) water stream, which can cause injury when the gun(s) are out of the water. **ALWAYS** keep the gun submerged when the engine is running.



Figure 5.1 – Engine Emergency Shut-Down and Throttle Control

NOTE: New generation Diesel engines with emission control requirements at a level “Tier 4F” in USA and “Stage V” in EU governed by computer systems with better electric control and higher redundancy of safety features DO NOT require an Emergency Stop Button.

5.4. Adjusting the CaviBlaster for maximum performance

The pressure at the nozzle of the zero-thrust gun has to be maintained within certain limits to achieve cavitation and for best performance results. If using a calibration pressure gauge situated between the pressure hose and the CaviBlaster gun, the water pressure should be 2,800-psi (193 BAR) with the gun submerged and the gun trigger in the open or “ON” position. For best results, repeat this calibration procedure if cleaning performance degrades, or every 3 months at a maximum.

	<p>A CALIBRATION TEST GAUGE IS RECOMMENDED WITH EVERY UNIT. CONNECT BETWEEN THE END OF THE PRESSURE HOSE AND THE WHIP HOSE OR GUN.</p>
--	---

To calibrate the pressure at the zero-thrust gun, follow the procedure below:

- Stop the power unit and pull the gun trigger to discharge any residual pressure in the hose lines.
- Disconnect the gun/DoubleDome with its whip hose from the main hose line.
- Attach the calibration gauge to the whip hose and tighten the JIC fitting.
- Reattach the whip hose with the gun/DoubleDome and calibration gage to the main hose and tighten the JIC fitting.
- Submerge the gun. Because of the danger of the operator coming in contact with either of the water streams from the cavitating or zero-thrust nozzles, **CaviDyne does NOT recommend calibrating the gun out of the water. Use extra care to avoid both water streams if doing so.**
- Ensure that both the cavitation and zero-thrust nozzles are pointed away from the diver's or operator's hands, arms and body.
- Pull the gun trigger to the open or "ON" position (See Figure 5.2).
- Start the power unit (See Section 5.3).
- Throttle the engine to full speed (See Section 5.3).
- Hold the gun tight and observe the calibration gauge (See Figure 5.2).
- The power unit operator should turn the knob on top of the pressure regulating valve until pressure reads 2,800-psi (193 BAR) on the calibration gauge. Turning the knob clockwise will increase the pressure and turning it counter clockwise will decrease the pressure.

To calibrate the pressure at the CaviBlaster power unit, the water pressure at the power unit will need to be higher to account for sidewall friction loss in the pressure hose. The pressure at the pump should be 2,800-psi (193 BAR) plus 0.5-psi per foot (0.11 bar per meter) of pressure hose. For example, if using the CaviBlaster with 100 feet (30 meters) of pressure hose, the pressure gauge located next to the pump should indicate 2,850-psi (196 bar). Pressure adjustments are made by turning the knob on top of the pressure regulating valve in the same manner as described above.



DO NOT ADJUST THE PRESSURE AT THE GUN TO MORE THAN 2,800-PSI. (193 BAR) HIGHER PRESSURE WILL NOT IMPROVE PERFORMANCE.

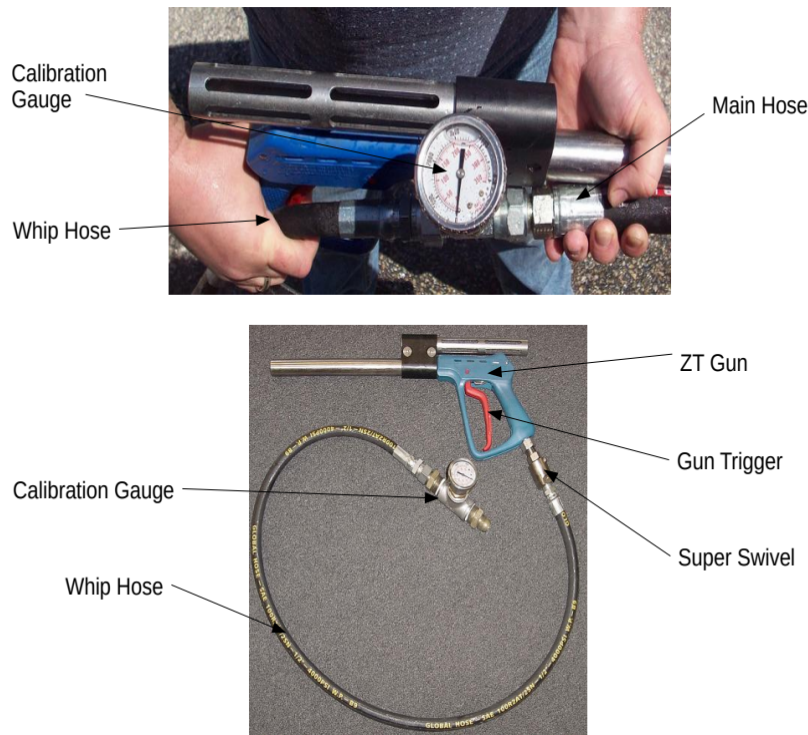

Figure 5.2 – Gun Pressure Calibration

5.5. Recommendations for Effective Results

Once the engine is throttled up to operating speed and the water trigger is pulled, the diver has to find the most effective distance between the gun nozzle and the surface being cleaned.

When the diver is ready to commence cleaning operations, ensure that the gun trigger is in the open or “ON” position (See Figure 5.3), the gun is submerged in the water and the feed pump is operating prior to throttling up the engine. Ensure that the power unit operator and other people working in the vicinity of the power unit wear appropriate hearing protection when the engine is running.

1. Engage the pressure pump by pulling the engine throttle lever (See Figure 5.1) to the operating speed position (fully extended) and tighten the thumb screw to hold throttle in operating speed position.

2. The DoubleDome nozzles are factory-set to the optimum cleaning position and require no further adjustment. The operator simply sets the DoubleDome flat on the surface to be cleaned and moves it in the desired direction.
3. The most efficient operating technique is to hold the nozzle 2-5 inches (5-12 cm) away from the surface to be cleaned and at a 25 to 45 degree angle to the surface being cleaned (See Figure 5.3). The diver needs to observe the shape of the cavitating jet cone. At greater depths, the higher ambient pressure will cause the jet cone to be shorter. The widest zone of the cone is the most efficient part of the cavitating jet. Placing the nozzle closer than 2 inches (5 cm) from the surface being cleaned will not allow for efficient cavitation performance and will degrade the cleaning capability of the CaviBlaster system.
4. Follow all safety regulations that may be applicable to the work being performed.
5. If the diver operating the CaviBlaster unit must be replaced or the cleaning operation must be terminated, disengage the pressure pump by pushing the throttle lever in to the idle position (See Figure 5.1) and release the water pressure remaining in the hose(s) by moving the gun trigger to the open or "ON" position while under water. Revert to step 1 of the operating instructions when the diver or replacement is ready to continue cleaning.

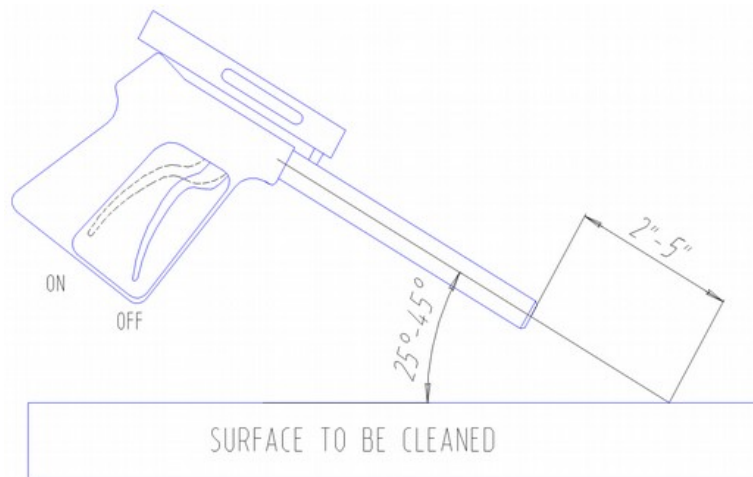

Figure 5.3 – Gun Position for Best Results

(EOS)

5.6 Shutting Down the CaviBlaster

1. Adjust the engine speed to idle by pushing on the red throttle cable knob (See Figure 5.1).
2. Run the engine at idle speed for a few minutes.
3. Shut off the engine by turning the ignition key to the “OFF” position (See Figure 5.1).
4. Push the feed pump ON/OFF switch in to stop the pump (See Figure 2.3). If using force feed from an alternate source or if using gravity feed, shut off the supply of water to the pressure pump.
5. **Squeeze the gun trigger to the open or “ON” position (See Figure 5.3) to release the water pressure remaining in the hose(s) while the gun is submerged.**
6. It is now safe to remove the gun from the water.
7. If using a DoubleDome, close the ball valve on the DoubleDome to stop the nozzles from rotating. After turning off the engine, release all pressure from the system by opening the ball valve on the DoubleDome before removing the DoubleDome from the water:
8. Flush the system and rinse the power unit with fresh water at the end of the day.

(EOS)

6.0 MAINTENANCE

Maintenance on this unit should be restricted to authorized personal that have been properly trained. Review this manual, especially Section 3.0 *SAFETY INFORMATION*, prior to performing any service on this equipment.



Equipment must be OFF prior to performing any service work.



Only replace parts with those supplied or approved by CaviDyne. Use of any other parts will void all warranties and may lead to equipment failure and severe personal injury.



CaviBlaster MUST BE FLUSHED AND RINSED WITH FRESH WATER AFTER EACH USE IN SEA WATER.



FAILURE TO FLUSH AND RINSE THE UNIT WILL RESULT IN PREMATURE WEAR AND TEAR ON THE COMPONENTS AND DECREASED SERVICE LIFE.



Failure to flush and rinse the unit can cause the pump valve(s) to stick in the open position. This will prevent the system from producing the correct operating pressure.

6.1 Basic Preventive Maintenance Recommendations

	After Every Use	Every 6 Months or 125 Hours*	Every 12 Months or 250 Hours*	Every 12 Months or 500 Hours*	Every 1,000 Hours
Check engine oil level and add if low	X				
Check pump oil level and add if low	X				
Check coolant level and add if low	X				
Check drive belt for wear and replace if worn	X				
Check feed pump strainer and clean if necessary	X				
Check in-line filter cartridge and clean/replace if necessary	X				
Inspect hoses for wear or damage ¹	X				
Check gun trigger for leakage and repair if necessary ²		X			
Check feed pump electric connections		X			
Replace engine oil and oil filter ³			X		
Replace engine fuel filter				X	
Replace engine air filter				X	
Replace pump oil ⁴				X	
Replace engine fan belt					X
Check pump valves and seals for wear & change if necessary					X

* Whichever occurs first.

- 1) If any hose damage is found, replace hose immediately.
- 2) Remove gun from water with system at operating pressure and trigger in the closed or "OFF" position. If water is leaking out of barrel or handle, the valve is worn and should be replaced.
- 3) The initial oil change is after 50 hours of operation. The oil change interval is every 125 hours if oil of a quality lower than prescribed by the manufacturer is used. See engine manufacturer's literature in the Appendix for additional recommendations.
- 4) The initial oil change is after 50 hours of operation. See pump manufacturer's literature in the Appendix for additional recommendations.

6.2 Diesel Engine Service

The diesel engine requires routine maintenance. Oil must be checked and changed regularly. Oil, air and fuel filters must be checked and changed regularly. The engine crankcase holds 2.5 gals. (10.0 L) and the oil filter an additional 0.2 qts. (0.2 L) of oil. For oil type and detailed information on these routine maintenance requirements as well as other service recommendations, please see the engine manufacturer's literature found in the *APPENDIX*.

6.3 Pump Service

The high pressure water pump requires minimal maintenance. The pump oil should be checked on a regular basis. The pump crankcase holds 89 oz. (2.6 L) of SAE 30 viscosity non-detergent hydraulic oil. See pump manufacturer's literature found in the *APPENDIX* for further information.

6.4 Inspection/Cleaning of Water Inlet Strainer and Filter

The CaviBlaster 2828 is equipped with a water inlet strainer and a water inlet filter, plus a strainer on the water feed pump suction. The feed pump inlet strainer should be inspected for debris and cleaned after each use. The process for inspecting and cleaning the strainer and filter mounted in the CaviBlaster is as follows:

Strainer.

- 1) Isolate or disconnect the water source from the inlet connection to the power unit.
- 2) Unscrew and remove the strainer cap (turn CCW) (See Figure 6.1).
- 3) Remove the strainer.
- 4) Inspect the strainer and flush any debris clean with clean water.
- 5) Push strainer back into housing.
- 6) Thread the strainer cap CW by hand to tighten.

Filter.

- 1) Isolate or disconnect the water source from the inlet connection to the power unit.
- 2) Unscrew the filter bowl from the filter head (turn CCW) (See Figure 6.1).
- 3) Pull filter bowl DOWN.
- 4) Remove the filter element.
- 5) Inspect the filter element and flush any debris clean with clean water.
- 6) Replace with a new filter element if necessary.
- 7) Push the filter element back into housing.
- 8) Push the filter bowl back onto filter head.
- 9) Turn the housing CW by hand to tighten.

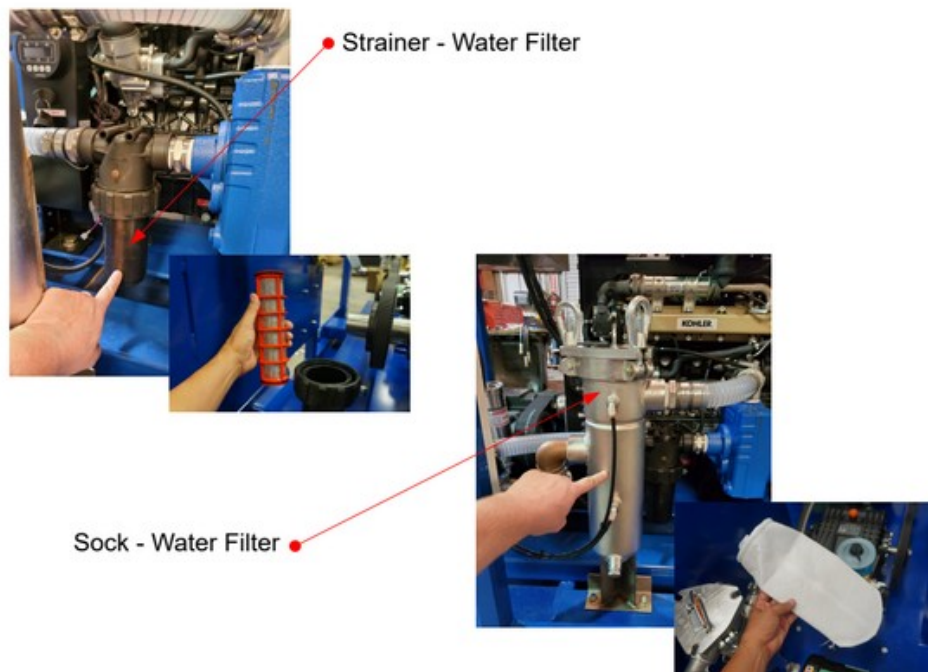
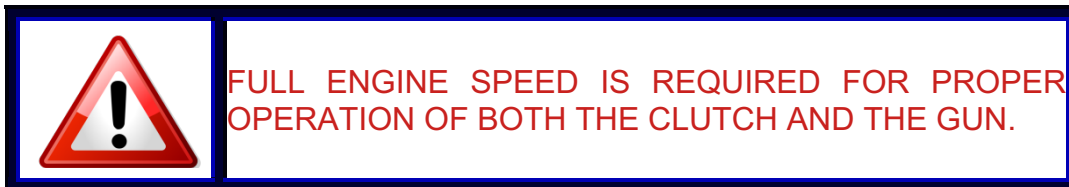

Figure 6.1 – Inspection / Cleaning Water Strainer/Filter

6.5 Inspection / Maintenance of the belt drive system

The CaviBlaster 2828 is equipped with belt power transmission. The driver shaft has a centrifugal clutch with 1,400 RPM engagement speed.



To inspect the belts:

1. Remove the belt cover (See Figure 6.2).
2. If belts need tightening, use the tightening nut to adjust (See Figure 6.3).
3. Release the bolts holding the pump rails.
4. Adjust Belt tension.
5. Tighten pump rails bolts.
6. Close belt guard.



Figure 6.2 – Inspection / Belt tension.

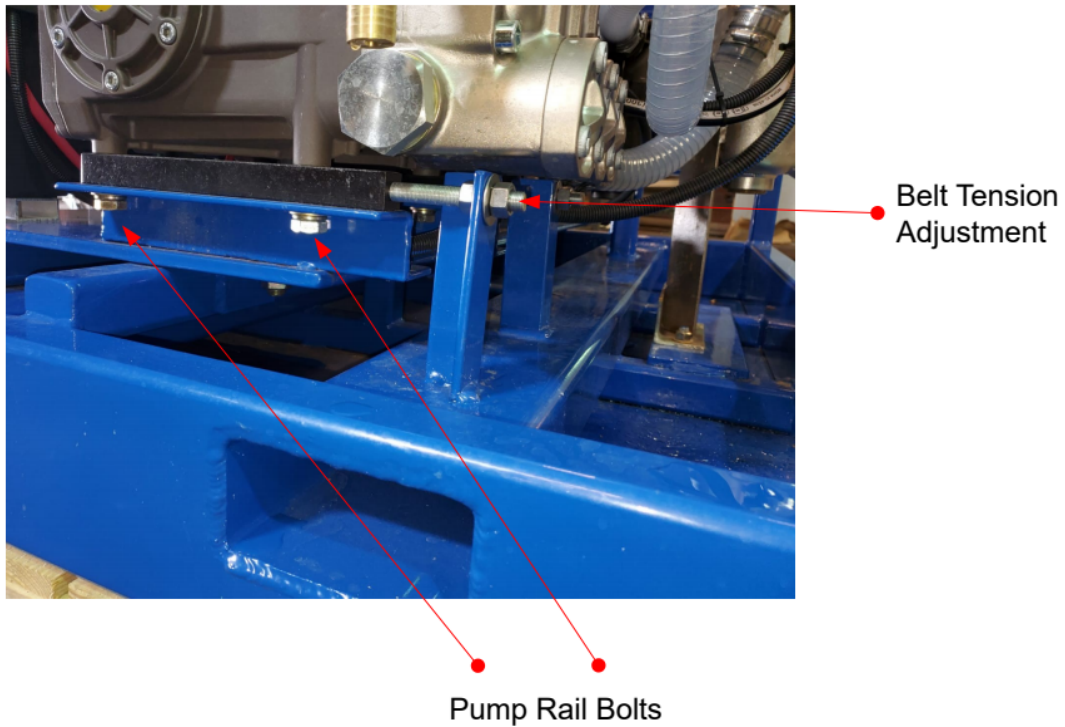

Figure 6.3 – Inspection / Belt tension.

(EOS)

6.6 Inspection / Maintenance of the Zero-Thrust Guns

In order to minimize potential problems with the Zero-Thrust Gun it is recommended that the used gun be treated at the end of each work period:

1. Flush and rinse the gun with fresh water after each use in sea water.
2. If the 1428 guns; 2828 dump gun; or DoubleDome will be used again within the next 24 hours, place the them in a container of clean, fresh water.
3. The 2828 dump gun is approximately 4ft (1.2M) long, if it cannot be completely submerged make sure it is thoroughly sprayed or washed.
4. If the DoubleDome cannot be completely submerged make sure it is thoroughly sprayed or washed.
5. If the either of the guns or the DoubleDome will not be used for a period of several days, remove the whip hose from the super swivel and, with the gun turned upside-down, pour approx. 5ml of lubricating oil into the water inlet while opening and closing the trigger. This will allow oil to reach the valve cone and minimize the possibility of corrosion or mineral crystals forming that would freeze the valve cone.
6. Do not use WD-40 for long term storage.



Figure 6.3 – 1428 Zero-Thrust Gun

(EOS)

7.0 WINTERIZATION

The power unit should be winterized only if temperatures drop below 32 degrees Fahrenheit (0 degrees Celsius).

Total system displacement with 100 ft of hose (optional): 4.3 gallons.
Total system displacement without hose: 2.0 gallons.

To winterize the CaviBlaster 2828 power unit:

1. Fill a 5 gallon or larger tank with appropriate antifreeze solution.
2. Set the tank above the water inlet on the control panel.
3. Connect the suction of the unit to the antifreeze tank.
4. Start the unit and make sure the pump is primed.
5. Attach a minimal amount of pressure hose and direct the outlet of the hose into the antifreeze tank.
6. Run the unit without gun attached until antifreeze comes out of the end of the hose for 10 seconds.
7. Stop the unit.

Following this procedure will ensure that all the critical system components exposed to water have been flushed with antifreeze.

(EOS)

8.0 TROUBLESHOOTING

1. ENGINE DOES NOT TURN OVER

- Verify that the battery terminals are clean and tight
- Verify battery charge
- Check the alternator belt tension

2. ENGINE TURNS OVER BUT DOES NOT START

- Verify that the throttle control cable is set to the engine start position
- Check fuel level
- Check fuel filter
- Check fuel line for air lock
- Verify that fuel pump solenoid is not stuck

3. ENGINE THROTTLES UP, BUT STALLS AFTER FEW SECONDS

- Verify that drive belts are tensioned (follow procedures in Section 6.5)
- Check that pressure regulator / unloader switches to by-pass mode
- Check mechanical stop on the throttle cable if at end position
- Check that the bolt connecting the throttle cable to the throttle lever is tight

4. ENGINE SPEEDS UP, BUT WATER DOES NOT GO OUT THE GUN

- Verify inlet water supply
- Ensure that the power unit is not located too far above the water level, exceeding the capacity of the feed pump
- Check that feed pump and inlet water strainers are clear
- Check for leaks in the water lines
- Check for an air-lock in the water inlet lines
- Verify that the feed pump is delivering water
 - Pump mechanical/electrical failure
 - Bad electrical connections
- Check that pressure pump inlet and discharge valves are not stuck open (common problem if not flushed after use with sea water)
- Check for water going out of the bypass – pressure regulator failure

6. WATER IN CRANK CASE

- Check the pump seals for damage (feeding water at greater than 70-psi (4.8 BAR) can force water past the seals and damage the seals)
- Check the plungers for cracks
- Check the plunger rod O-ring

7. AFTER RELEASING THE MECHANICAL TRIGGER, WATER IS STILL LEAKING OUT OF THE GUN

- Replace the mechanical trigger valve assembly in the gun handle

8. GUN IS NOT CLEANING PROPERLY

- Verify that the system is operating at the correct pressure (2,800-psi, 193 BAR)
- Remove the gun from water with the system at operating pressure and trigger in the closed or "OFF" position. If water is leaking out of the barrel or handle, the trigger valve assembly should be replaced
- Check cavitation and zero-thrust nozzles for foreign particles
 - Visual inspection
 - Insert a small wire into nozzle orifices to check for obstruction(s)
 - Remove trigger valve assembly and "backflush" with compressed air or pressurized water.

9. SMOKING/BLACK EXHAUST, FEW REASONS COULD CAUSE THIS:

- The muffler clogged with soot, or the spark arrestor plated been tightened too much, on the top of the muffler is a nut and it should not be too tight.
- Muffler configuration is not efficient in some atmospheric conditions.
- Air filter is clogged or some other way restricting the air flow.
- Fuel /type condition is not matching the engine requirements.
- Fuel filter is clogged. (Also, just for test purpose you can take off the muffler and run the engine, and see the results.)

10. PRESSURE PUMP, CAVITATION/UNIT SHAKING, HOSE DAMAGE:

- Lack of water to be delivered to the pressure pump.
- Check the feed pump
- Check all electric connections, especially the spliced buds that connect wires out the pump and the extension wires that go to the control panel.
- Check both filters, make sure there is no restriction on the water flow.

(EOS)

9.0 REPLACEMENT PARTS

CaviBlaster 2828 POWER UNIT REPLACEMENT PARTS			
RECOMMENDED ORDER QTY	QTY USED PER ASSEMBLY	PART DESCRIPTION	PART NUMBER
1	1	Feed pump inlet strainer	
1	1	Inlet strainer cartridge	
1	1	Inlet filter element	
1	1	Engine air filter	
2	1	Engine oil filter	
1	1	Engine fuel filter	
1	1	Timing belt	
1	1	Alternator belt	
2	1	Drive belt	
1	1	Seal kit	04-KIT-139
1	1	Valve kit	04-KIT-142
1	1	Plunger rod o-ring kit	
1	1	Pressure regulating unloader repair kit	
1	1	Relief valve repair kit	
1	1	Trigger valve assembly repair kit	202700490

All parts can be
ordered from:

CAVIDYNE LLC

5077 Fruitville Rd., Suite 109-157
Sarasota, FL 34232
Phone: (352) 275-5319
www.cavidyne.com

APPENDIX - COMPONENT LITERATURE

<p>Kubota Diesel Engine Model V2403</p>	<p>Engine Spec Sheet Engine Owner's Manual Engine Work Shop Manual Engine Troubleshooting Guide</p>
<p>Udor Pump Model VX-100/200</p>	<p>Pump Spec Sheet Pump Exploded View Pump Dimensions Pump Service Guide Pump Torque Specs</p>
<p>Udor Pressure Regulating Unloader & Relief Valve Model UB402</p>	<p>Valve Spec Sheet</p>
<p>Suttner Trigger Gun Model ST-2700 SS</p>	<p>Gun Schematic Drawing</p>

<p>Warranties</p>	<p>Cavidyne Kubota Engines Udor USA Suttner Johnson Pumps</p>
--------------------------	---

(EOS)