



CAVIBLASTER[®]

**Operation &
Maintenance
Manual**



Model 0625-G

Model 0625-G – Manual

Operating Instructions



WARNING: To ensure operator safety and efficient operation of the CaviBlaster®, it is essential to follow these instructions.

Preparing the CaviBlaster system for operation:

1. Inspect the CaviBlaster® power unit, hose and gun for any signs of damage.
2. Inspect Inlet Strainer (Figure-1) to ensure that it is not dirty or clogged. Clean as necessary.



Water Inlet - Figure #1

3. Check lubricating oil(s) and fuel levels: Assure proper oil level in engine crankcase, pressure pump and fuel level in fuel tank (gasoline). Figures 2, 3, 4.



Engine Oil Level - Figure #2
Pump Oil Level - Figure #3



Fuel Level - Figure #4



4. Fill lubricating oil(s) to proper level(s) in the pressure pump (Yellow cap on pump) (Figure-5) and engine (Yellow cap on head cover) (Figure-6) per manufacturers' operating manuals.



Pump Oil Yellow Cap - Figure #5



Yellow Cap on head cover - Figure #6

NOTE: Pressure Pump Oil (SAE 30W-Non-Detergent) Figure-7; Engine Oil (SAE 10W 30) Figure-8



Pressure Pump Oil - Figure #7



Engine Oil - Figure #8

5. To provide water to the Model 0625-G CaviBlaster® power unit, connect feed pump to the water inlet connection on the power unit (Figure-9).



Connect Feed Pump to Water Inlet - Figure #9

Inspect inlet connection (Figure-10) to ensure that it is not clogged. Clean if necessary



Connect Feed Pump to Water Inlet - Figure #10

When feeding water to the CaviBlaster® power unit with the feed pump, connect the 1" diameter clear PVC feed hose to the cam-lock plug on the inline strainer inlet.

The feed hose has the feed pump on one end and a cam-lock socket on the other end. Insert the electrical plug powering the feed pump into the waterproof electrical outlet on the end of the power unit cart under the handle. Ensure that the knob on the plug is facing up and mates with the notch in the outlet cover. *If the plug is engaged upside down, the pump will turn in reverse.* **Ensure that the feed hose is connected to the pressure pump, the feed pump is submerged in water, and the wiring splice is kept dry prior to starting the feed pump.** Either fresh water or seawater can be used with this system.

Note: The feed pump has had a neoprene check valve installed in the discharge. This valve will prevent water from draining out of the feed hose through the feed pump when the pump is turned off. However, this check valve somewhat restricts the flow of water from the pump. If maximum water flow is required from the feed pump, the check valve and stainless retaining washer can be removed from the pump discharge by removing the black hose barb fitting. **NEVER TURN OFF FEED PUMP WHILE WORKING.**



When feeding the CaviBlaster® with an alternate water source, **the source must supply water at a volume of greater than 6 gallons per minute at a maximum pressure of 70-psi.** Connect the water source to the inlet of the pressure pump (Figure 10). **Ensure that the feed hose is connected to the pressure pump and the water is on prior to starting the pressure pump.**



Starting the CaviBlaster® power unit:

1. Start the feed pump and place in one feet of water, at the water source.
2. Ensure that the system is primed with water and that there are no leaks in the system. The pressure pump is a positive displacement pump and water must be supplied under pressure. Failure to pump feed water to the pressure pump will result in damage to the pump.
3. Connect the 3/8" high-pressure hose to the quick-connect plug under the pressure-regulating unloader (Figure-11). The high-pressure hose has a brass quick-connect socket on the end. The CaviBlaster® Model 0625-G can deliver the required pressure utilizing up to 300 feet of 3/8" diameter rubber hose.



Connect HP Hose to the quick connect under pressure regulator - Figure #11

4. Move throttle to the On position (figure 12) and fully engage choke (figure 13) and then turn the key to start engine (figure 14).



Throttle at the On position - Figure #12



Fully engage Choke - Figure #13



Ignition key - Figure #14

5. Connect the gun to the high-pressure hose (Figure-15) and submerge the gun in water.



Connecting the gun to the High Pressure Hose - Figure #15

6. It is recommended that the gun trigger be in the open or “ON” position when starting the engine. This will prevent a pressure shock wave from damaging the pump in the instant that the engine is started.



7. Divers and nearby personnel must use appropriate hearing protection prior to starting the engine.

8. Be sure the engine run switch is on (figure 12). Set the choke knob to close the choke if the engine is cold or has not been running (figure 13). If the engine has been running and is warm, leave the choke open. Adjust the throttle lever (Figure 12) one-third of the way from “MIN” toward “MAX” for correct engine start RPM. Turn the ignition key, (figure 14) (several times as necessary) until the engine starts. If the engine does not start, release the choke and try again.

9. Once the unit is running and warm, move the throttle to Max. (figure 16)

The system is now ready to operate. (figure 17)



Throttle to Max position - Figure #16



Overall system set up - Figure #17

Recommendations for Effective Results.

Once the engine is throttled up to operating speed and the water trigger is pulled, the diver should find the most effective distance between the gun nozzle and the surface being cleaned. When the diver is ready to commence cleaning operations, ensure that the gun trigger is in the open or "ON" position, the gun is submerged in the water and the water source is on, prior to throttling up the engine.

Ensure that the power unit operator and other people working in the vicinity of the power unit wear appropriate hearing protection when the engine is running.

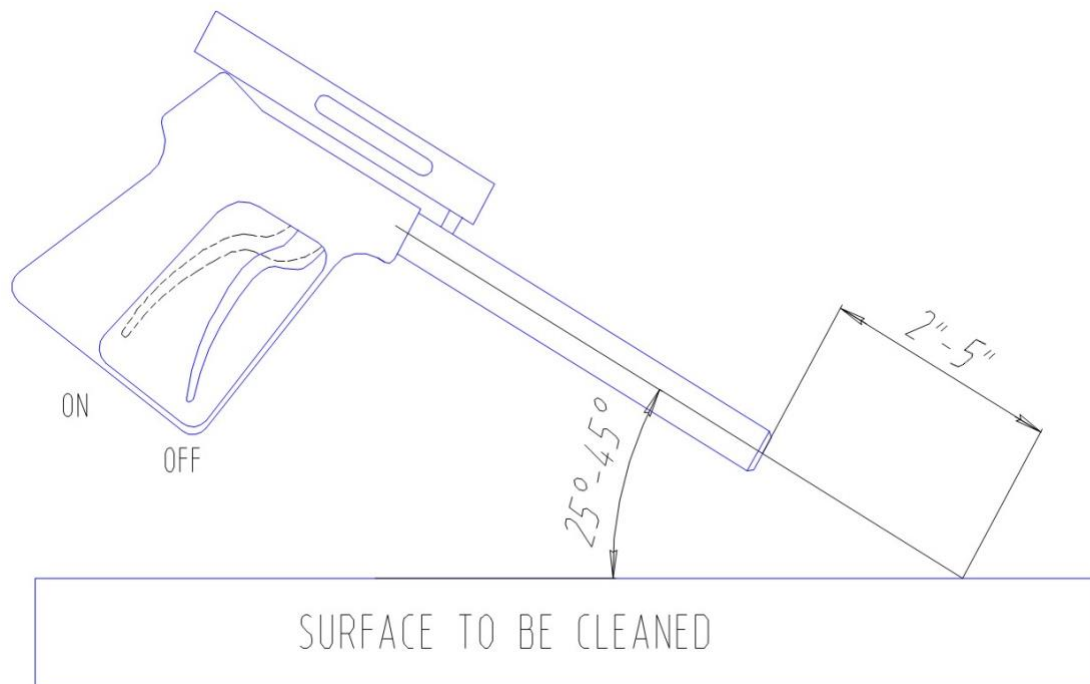

Gun efficient operating technique - Figure #18

1. The most efficient operating technique is to hold the nozzle 2-5 inches (5-12 cm) away from the surface to be cleaned and at a 25° to 45° angle to the surface being cleaned. The diver needs to observe the shape of the cavitating jet cone. At greater depths, the higher ambient pressure will cause the jet cone to be shorter. The widest zone of the cone is the most efficient part of the cavitating jet. Placing the nozzle closer than 2 inches (5 cm) from the surface being cleaned will not allow for

efficient cavitation performance and will degrade the cleaning capability of the CaviBlaster® system.

2. Follow all safety regulations that may be applicable to the work being performed.

3. If the diver operating the CaviBlaster® unit must be replaced or the cleaning operation must be terminated, disengage the pressure pump by pulling down the throttle lever in to the idle position and release the water pressure remaining in the hose(s) by moving the gun trigger to the open or “ON” position while under water. Revert to step 1 of the operating instructions when the diver or replacement is ready to continue cleaning.



WARNING: Although the CaviBlaster® system is safe to use when submerged in water, the system generates a high pressure (up to 2,500-psi) water stream, which can cause injury when the gun is out of the water. ALWAYS keep the gun submerged when the pressure pump is engaged.

Operating the CaviBlaster® system:

1. When the diver is ready to commence cleaning operations, ensure that the gun is submerged in water. Then move the throttle lever up to adjust the engine RPM to “MAX”.
2. Ensure that the power unit operator and other persons working in the vicinity of the power unit wear appropriate hearing protection when the engine is running. If the diver is not wearing a helmet, hearing protection is recommended. CaviDyne™ recommends “Doc’s Proplugs” vented earplugs or equivalent for diver hearing protection.
3. Activate the cleaning cavitation stream by squeezing the trigger to the open or “ON” position.
4. The most efficient operating technique is to hold the gun 2-3 inches away from the surface to be cleaned and at a 25° to 45° angle to the surface being cleaned. Placing the gun closer than 2-3 inches from the surface being cleaned will not allow for efficient cavitation performance and will degrade the cleaning capability of the system. (Figure-18).
5. Wear neoprene or rubber gloves to protect the hands and follow all safety regulations that may be applicable to the work being performed.
6. If the diver operating the unit must be replaced or the cleaning operation must be interrupted or terminated, shut down the engine by moving the throttle lever down to adjust engine RPM to “MIN” (Figure 16) and turning the engine to the “OFF” position (figure 12). Turn off the water feed and then release the water pressure in the hose(s) by squeezing the gun trigger to the open or “ON” position **while under water**. Revert back to step 1 of the operating instructions when the replacement diver is ready to continue cleaning.
7. Ensure that the gun is submerged any time the engine and pressure pump are operating.

Adjusting the CaviBlaster® system for maximum performance:

Recommended Calibration Method

1. Using the **optional** calibration pressure gauge set, situated between the pressure hose and the CaviBlaster® gun, the output water pressure should be adjusted to 2,500 PSI, with the gun submerged and the gun trigger in the open or “ON” position. The pressure is adjusted by turning the black knob on the end of the pressure-regulating unloader (Figure 19). This adjustment increases or decreases the flow of water through the bypass hose when the CaviBlaster® gun trigger is in the open or “on” position. The flow of water through the bypass hose, in turn, determines the flow of water through the pressure hose and the gun. Less flow through the bypass hose means more flow through the gun which translates to higher velocity and pressure. There should always be a trickle of water through the bypass when the gun trigger is in the open or “ON” position. This ensures that the bypass will open without a pressure shock wave damaging the pump when the gun trigger is released to the closed position.



Pressure Regulator Knob - Figure #19

Shutting down the CaviBlaster® power unit:

1. Adjust engine RPM to “MIN” (Figure 16).
2. Shut off the engine by turning the run switch to the “OFF” position (Figure 12).
3. Squeeze the gun trigger to the open or “ON” position to release the water pressure remaining in the hose(s) while the gun is submerged.
4. It is now safe to remove the gun from the water.
5. Flush the system and rinse the power unit with fresh water at the end of the day.

Maintenance of the CaviBlaster® unit:

1. Check the oil level and consistency in the engine and pressure pump every day.
2. Flush the system and rinse the power unit with fresh water after each days use, for at least 5 minutes, to make sure all inside residuals are removed.
3. Change the engine oil after the first month or 20 hours and every six months or 100 hours thereafter. Replace the oil filter every 200 hours. Use SAE 10W-30 oil for general all- temperature use.
4. Clean the air cleaner cover, filter elements and base every three months or 50 hours. Replace the paper filter element every twelve months or 300 hours or if damaged or excessively dirty.
5. Change the oil in the pressure pump after the first 50 hours and every 500 hours thereafter. Use single-weight lubricating oil (SAE 30 weight non-detergent)
6. Change the spring for the gun trigger every 12 months or less as required.

Summarizing the operating instructions:

1. Inspect the system for damage. Check oil/fuel levels.
2. Attach the Feed hose to the unit, **NEVER TURN OFF PUMP WHILE WORKING**
3. Start water supply and ensure that the system is primed.
4. Attach the gun to the pressure hose.
5. Make sure that the diver is ready to work and that the gun is submerged in the water.
6. Apply hearing protection, start the engine and adjust the throttle to "MAX."
7. Activate the cleaning cavitation stream by squeezing the gun trigger to open or "on."
8. Proceed with cleaning.
9. When cleaning is complete, shut off the unit.
10. Release pressure from the hose(s) by squeezing the gun trigger to the open or "ON" position while under water.
11. Remove the gun from the water.
12. Flush the system and rinse the outside of the power unit with fresh water.

WARNING: While the CaviBlaster® system is very safe, operators should exercise care when using this equipment. With the diver lance underwater, the cavitation "flame" can be safely passed over the operators' skin at normal operating distances of 2" – 3" from the tip of the nozzle. However, at very close distances (typically less than 1") both nozzles can cause harm to the operator, particularly in the initial instant that the system is activated. For that reason, operators should exercise caution when operating the gun with the nozzles in close proximity to the body. The operators should also ensure that the reverse-thrust nozzle guard is secured in the correct position prior to operating the gun. The operators of the CaviBlaster® system should always wear neoprene or heavy rubber gloves to provide protection to the hands and, in particular, to the nails. The gloves will absorb most of the energy produced by bursting cavitation bubbles and prevent the cavitation bubbles from contacting the operators' hands. The gloves will also protect operators' hands from the initial shockwave when the

gun is activated. Serious harm and injury may result from the misuse of CaviBlaster® system equipment or improperly selected fittings, hoses or attachments. All components of the system should be checked against the manufacturers' instructions to ensure that they are compatible with the pressures being used and of the correct thread type and pressure rating for the intended service. Refer to these Operating Instructions and to the engine and pressure pump manufacturers' operation manuals for instructions or call CaviDyne, LLC at (352) 275-5319 with any questions.



CAUTION: DO NOT USE IT TO CLEAN SENSITIVE SURFACES as LED-Lights, Underwater Lights, Electronic Equipment, Etc.