



***CAVI*BLASTER<sup>®</sup>**

CAVIDYNE, LLC

5077 Fruitville Rd.; Ste 109-157  
Sarasota, FL 34232

Phone: (352) 275-5319  
[www.caviblast.com](http://www.caviblast.com)

# Operation & Maintenance Manual

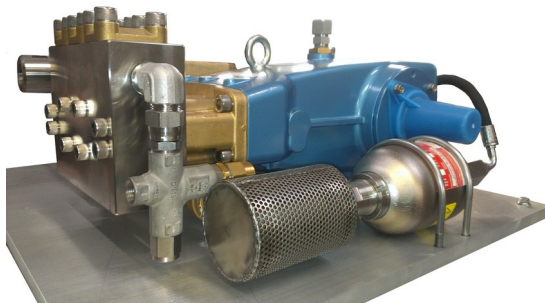

**Model 2040-ROV**



CAVIDYNE LLC is not responsible for damages or injuries resulting from a failure to comply with instructions in this manual. Please read and study the entire manual carefully before use.



The CaviBlaster 2040-ROV must only be operated and maintained by trained personnel.



This equipment generates high pressure water and is intended for underwater use only. **Serious personal injury or death may result from improper use.**

# TABLE OF CONTENTS

<b>1.0 UNIT SPECIFICATIONS.....</b>	<b>5</b>
<b>2.0 GENERAL DESCRIPTION.....</b>	<b>6</b>
2.1 Using this Manual.....	7
2.2 Conventions.....	8
2.3 Scope.....	8
2.4 Terms and Abbreviations.....	8
<b>3.0 SAFETY INFORMATION.....</b>	<b>9</b>
3.1 Personal Safety.....	9
3.2 Personal Protective Equipment.....	10
3.3 Modification to the Equipment.....	11
<b>4. 0 INSTALLATION.....</b>	<b>12</b>
4.1 Uncrating and Lifting.....	12
4.3 Initial Set-Up.....	13
<b>5.0 OPERATION.....</b>	<b>14</b>
5.1 Preparing the CaviBlaster for Operation.....	14
5.2 Startup of the CaviBlaster.....	15
5.3 Normal Operation.....	15
5.4 Adjusting the CaviBlaster for Maximum Performance.....	16
5.5 Recommendations for Effective Results.....	19
<b>6.0 MAINTENANCE.....</b>	<b>21</b>
6.1 Basic Preventive Maintenance Recommendations.....	22
6.3 Pump Service.....	22
6.4 Inspection/Cleaning of Water Inlet Strainer.....	22
<b>8.0 TROUBLESHOOTING.....</b>	<b>23</b>
<b>9.0 REPLACEMENT PARTS.....</b>	<b>24</b>
<b>APPENDIX - COMPONENT LITERATURE.....</b>	<b>25</b>

## LIST OF FIGURES & TABLES

<i>Figure 1.1 – CaviBlaster 2040-ROV Specifications.....</i>	<i>7</i>
<i>Figure 2.1 – CaviBlaster 2040-ROV General Features.....</i>	<i>12</i>
<i>Figure 4.1 – Lifting Guidelines.....</i>	<i>18</i>
<i>Figure 5.2 – Lance Position for Best Cleaning results.....</i>	<i>19</i>

**This space intentionally left blank**

## 1.0 UNIT SPECIFICATIONS

---

The CaviBlaster 2040-ROV power unit consists of a 55HP (37 kW) Cross hydraulic gear motor power-pack and a CAT 3560 triplex plunger pump. Detailed performance and specifications are listed below:

<b>CaviBlaster 2040-ROV Specifications</b>	
Nominal Pump Flow	20 GPM (76 LPM)
Nozzle Operating Pressure	4,000-PSI (275 BAR)
Driver	50M052 Cross Hydraulic Gear Motor
Installation Environment	Submersible
Hydraulic Oil Flow Requirements	*See below.
Overall Unit Dimensions (L x W x H)	30" x 28" x 13" (76 cm x 71 cm x 33 cm)
Maximum Pressure Hose Length	300 LF (100 meters) of 3/4" (1.9 cm) diameter
Power Unit Weight (Dry)	273 LBS (124 KG)

*\*Hydraulic Power Unit must be capable of operating the water pressure pump at 1160 rpm and 55 HP. Consult CaviDyne regarding the suitability of your existing Hydraulic Power Unit.*

*Figure 1.1 – CaviBlaster 2040-ROV Specifications*

**This space intentionally left blank**

**(EOS)**

## 2.0 GENERAL DESCRIPTION

---

The CaviBlaster 2040-ROV high-pressure water power unit allows the operator to use the water flow and pressure to generate cavitation at the end of the proprietary nozzle.

The CaviBlaster cleans the surface of any underwater structure using the energy released by the implosion of the bubbles during the cavitation process. When directed at the surface being cleaned, the energy released by the collapsing bubbles causes marine growth to be removed from the surface.

The system consists of a portable high-pressure pumping unit designed for submersible ROV use and a high pressure cavitation lance (connected to ROV manipulator) with connecting high pressure hose.

The CaviBlaster 2040-ROV power unit is a complete “plug and play” system built on a supporting platform that allows quick deployment and/or installation of the unit. Water is supplied directly from the unit operating environment.

The unit is equipped with many features to maintain safety while operating at pressures of 4,000-psi (275 bar).



**CAVIBLASTER®**

***For more information on the CaviBlaster system please visit us at:  
[www.caviblasters.com](http://www.caviblasters.com)***

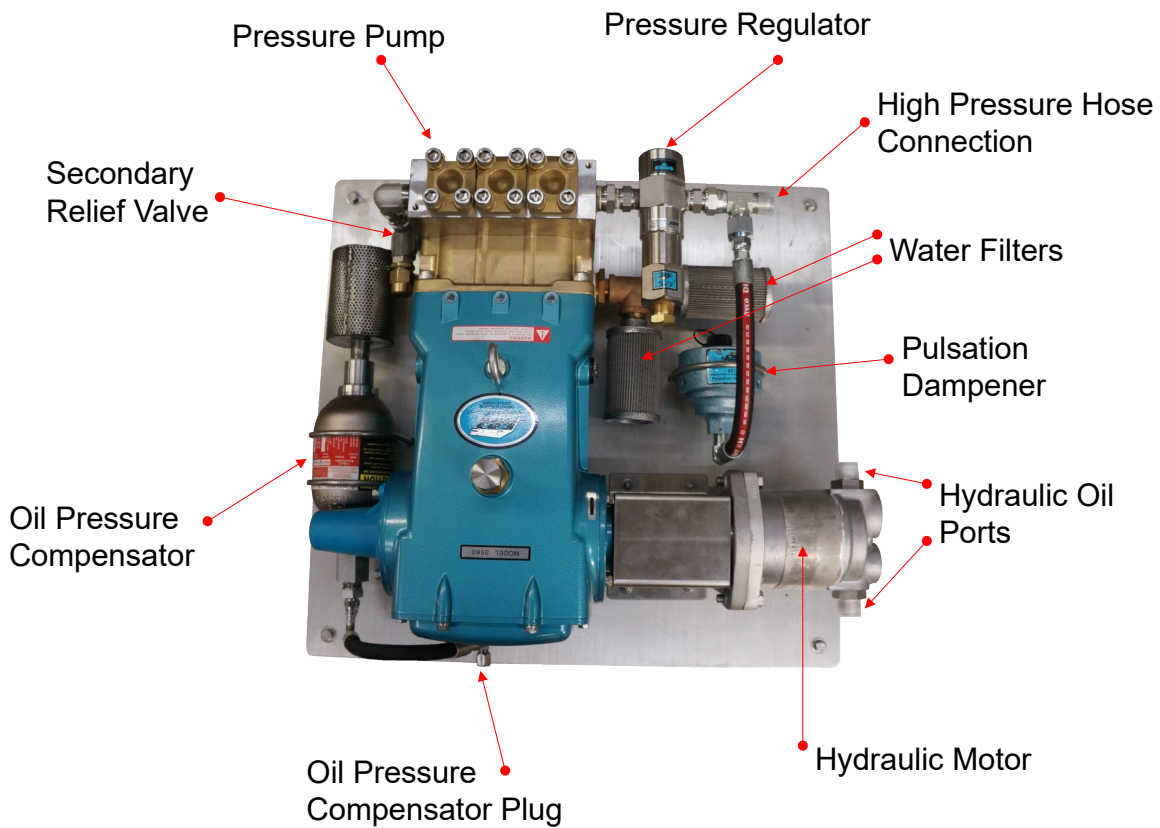

*Figure 2.2 – CaviBlaster 2040-ROV General Features*

## 2.1 Using this Manual

Every attempt has been made to ensure that this documentation is complete and accurate at the time of publication. It is imperative; however, that anyone attempting to use this manual must have good comprehension of how this equipment operates. Further, this manual can in no way replace the common sense of an individual. If at any time this manual seems to contradict itself, or common sense, discontinue the procedure, re-read the section, and seek assistance from CaviDyne or other personnel familiar with the operation of this equipment.

## 2.2 Conventions

The first time a component is mentioned, it is typically followed by a figure reference; e.g., Emergency Stop button (See Figure 2.1). Figure numbers and section numbers are always coincident.

When other sections are referenced the *SECTION NAME* will appear in italic caps. The electronic version allows users to click on the section name or figure reference to jump to that section. The words “**This space intentionally left blank**” will appear where there is more than 3 inches of white space.

**(EOS)** will appear above the page number on the last page of each section.

## 2.3 Scope

This manual covers installation, operation, and maintenance of the CaviBlaster 2040-ROV. It is essential that personnel who will operate and/or service this equipment familiarize themselves with this manual. Standard components, such as the unit engine and pump, are covered by the manufacturer’s literature found in the Appendix.

## 2.4 Terms and Abbreviations

CCW	Counterclockwise
CW	Clockwise
EOS	End of Section
GPM	Gallons Per Minute
HP	Horsepower
LPM	Liters Per Minute
PPE	Personal Protective Equipment
PSI	Pounds Per Square Inch (without suffix, assumed to be gauge pressure).

**(EOS)**



### 3.0 SAFETY INFORMATION

---

The CaviBlaster 2040-ROV power unit is an inherently powerful and potentially dangerous piece of equipment; however, with proper care and training it can be operated safely. The 2040-ROV must only be operated by personnel that have read and understand this manual. It is intended to reinforce and review safety techniques to prevent personal injuries and property damage.

Users must comply with all local, state, and national laws concerning high-pressure water jetting equipment as well as all underwater work regulations.

It is strongly recommended that this entire manual be reviewed in-depth before operating or servicing this equipment. Service work should only be performed by individuals who are proficient in using this equipment. Refer to the applicable section in this manual for the correct procedures prior to any installation, setup, or maintenance work.

Note that the oil pressure compensator is not a pressurized component and therefore not a safety hazard. It is open at one end and connected to the pressure pump oil chamber at the other end. Its purpose is simply to balance the oil pressure in the water pressure pump with the unit's surrounding environmental pressure to prevent damage to the water pressure pump.

#### 3.1 Personal Safety

Operation of the CaviBlaster 2040-ROV underwater submersible ROV-mounted cleaning system must only be operated by personnel who have been trained in its use. Operation of the system without the proper training can result in property damage and damage to the CaviBlaster unit.



CaviDyne, LLC is not responsible for damages resulting from a failure to comply with instructions in this manual. Please read carefully before use.



If maintenance or repair of the CaviBlaster is being conducted out of the water, remember that the unit generates a high pressure water jet stream. Never direct the jet stream at a person or animal. Never direct the jet stream toward power lines or other high voltage equipment.



Ensure that there is a safe area to work while operating or maintaining the CaviBlaster 2040-ROV.



Seek immediate medical attention if the operator suffers an injury as the result of contact with the high-pressure water stream. **Serious personal injury can result from an untreated water injection wound.**

### 3.2 Personal Protective Equipment

Always wear appropriate Personal Protective Equipment (PPE) when performing maintenance or calibration on this equipment.

Personnel operating or working in the vicinity of the power unit should wear appropriate hearing protection when operating the CaviBlaster during maintenance or calibration procedures.

Personnel performing maintenance or calibration procedures on the CaviBlaster 2040-ROV system should always wear neoprene or heavy rubber gloves to provide protection to the hands and, in particular, to the nails. The gloves will absorb most of the energy produced by bursting cavitation bubbles and prevent the cavitation bubbles from contacting the operators' hands. The gloves will also protect operators' hands from the initial shockwave when the lance is activated.



Failure to wear appropriate PPE may result in personal injury.

### 3.3 Modification to the Equipment

Do not make any unauthorized modifications or repairs to this equipment. Components used throughout this assembly were specifically designed or selected to safely meet the unique high-pressure requirements. Only replace parts with those recommended by or supplied by CaviDyne. Any unapproved modifications will void the equipment warranty. Unauthorized modification or part substitution can result in serious personal injury or property damage.



**This space intentionally left blank**

**(EOS)**

## 4. 0 INSTALLATION

---

The CaviBlaster 2040-ROV must be securely attached to the ROV using the vibration mounts supplied or other secure fastening mechanism.

### 4.1 Uncrating and Lifting

Unpack the equipment and inspect for damage. If damage is found, immediately contact CaviDyne and the shipping company. *If the unit will not be installed immediately, provide adequate indoor storage to protect against damage.*

The CaviBlaster power unit should be lifted from underneath. Do not use components of the CaviBlaster to lift the entire unit.

DO NOT LIFT FROM ANY COMPONENT OF THIS UNIT

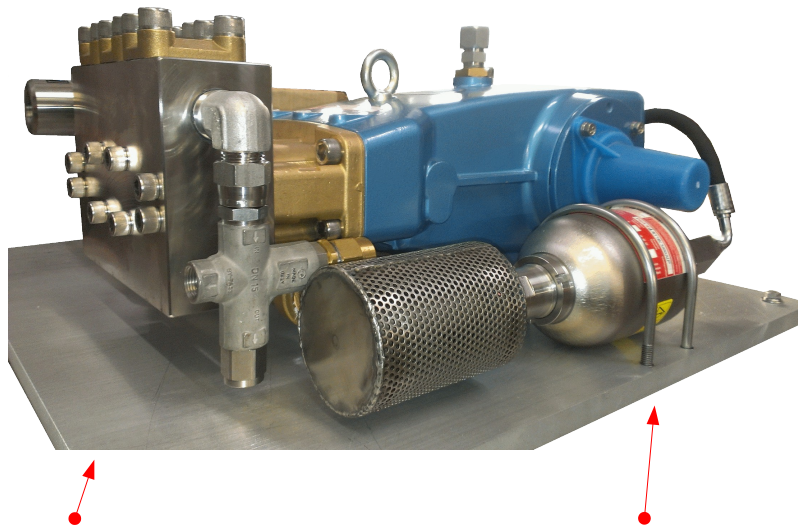

Lift this unit ONLY from the Base Plate, from Underneath

*Figure 4.3 – Lifting Guidelines*

### 4.3 Initial Set-Up

After first receiving the CaviBlaster power unit, the following must be completed:  
See Figures 2.1 for item locations.

1. Add oil to pump by completely filling pump to top of fill port.
2. Install fill plug.
3. Stand unit on end with pump motor at top.
4. Remove oil pressure compensator fill port cap.
5. Fill oil pressure compensator and hose with oil.
6. Allow unit to sit for several minutes to vent any trapped air.
7. Top-off oil as required.
8. Replace oil pressure compensator fill port cap.
9. Set unit back down on vibration mounts.
10. It is important that there is no air trapped in the pump oil system.
11. Connect hydraulic power unit hoses.
12. Connect water pressure hose.



**Pump fluids may have been removed for shipment. Check ALL fluid levels prior to starting.**



The CaviBlaster 2040-ROV can be used with seawater but must be flushed and rinsed with fresh water after every use in seawater. Failure to flush and rinse the power unit after use in seawater will result in increased wear and tear on components and can cause the pump valve(s) to stick in the open position. This will prevent the system from producing the correct operating pressure.

**(EOS)**

## 5.0 OPERATION

---



The CaviBlaster 2040-ROV should only be operated by properly trained personnel who are familiar with the contents of the manual. Review the safety requirements found in Section 3 before operating.

### 5.1 Preparing the CaviBlaster for Operation

The following checklist should be completed in advance, so that the unit is always ready for immediate use. This should be completed after each use.

- 1) Inspect the CaviBlaster power unit, hoses, JIC fittings and lance for any signs of damage.
- 2) Inspect the water inlet strainer to ensure that it is not clogged (See Figure 2.1). Clean if necessary.
- 3) Check for proper pressure pump oil level (See pump Owner's Manual found in the *Appendix*). Add oil (SAE 30 non-detergent) if necessary. **PUMP MUST BE COMPLETELY FILLED.**



Incorrect oils should not be used as they may damage the equipment.

## 5.2 Startup of the CaviBlaster

Before starting the CaviBlaster 2040-ROV unit, review all safety requirements found in Section 3.0 *SAFETY INFORMATION*. This equipment should only be operated by individuals who have read and understand the CaviBlaster Operation and Maintenance Manual.

- 1) Verify that the unit has been properly prepared for operation as described in Section 4.0 *INSTALLATION*.
- 2) Verify that the lance is properly connected to the CaviBlaster and the ROV.
- 3) Run the ROV hydraulic system to verify that the CaviBlaster hydraulic motor and pressure pump are functioning correctly.

## 5.3 Normal Operation

Normal operation of the CaviBlaster system is defined as user control of water flow via the lance. In the absence of a diver, control of the power unit is accomplished by the ROV manipulator. Should a problem develop with the control valve, discontinue using the CaviBlaster until fixed.



**Review the safety requirements for PPE and safe operation before proceeding.**

- 1) The ROV hydraulic system needs to be operating at a capacity that matches the water pressure pump requirements for the CaviBlaster 2040-ROV to function correctly. Unlike gasoline or diesel engines, a hydraulic motor will run as fast as the oil supply it receives, which means that the hydraulic oil supply must be adjusted to match the water pressure pump requirements. Consult with CaviDyne to determine if your high pressure oil supply unit is suitable for use with the CaviBlaster 2040-ROV.
- 2) Activate the cleaning cavitation stream by turning ON the hydraulic power unit.



Although the CaviBlaster system is safe to use when submerged in water, the system generates a high-pressure (up to 4,000-psi [275 bar]) water stream, which can cause injury when the lance is out of the water. **ALWAYS** keep the lance submerged when the pressure pump is engaged.

## 5.4 Adjusting the CaviBlaster for Maximum Performance

The pressure at the nozzle of the lance has to be maintained within certain limits to achieve cavitation and for best performance results. If using a calibration pressure gauge situated between the pressure hose and the CaviBlaster lance, the water pressure should be 4,000-psi (275 bar) with the lance submerged and the hydraulic power unit operating. For best results, repeat this calibration procedure if cleaning performance degrades, or every 3 months at a maximum.



**A CALIBRATION GAUGE IS RECOMMENDED WITH EVERY UNIT. CONNECT BETWEEN THE END OF THE HOSE AND THE LANCE.**

To calibrate the pressure at the lance, follow the procedure below:

- Stop the hydraulic power unit to discharge any residual pressure in the hose lines.
- Disconnect the lance from the main hose line.
- Attach the calibration gauge between the main hose line and the lance and tighten the JIC connections. (See Figure 5.1)
- Submerge the lance. Because of the danger of the operator coming in contact the water stream from the cavitating nozzle, **CaviDyne does NOT recommend calibrating the lance out of the water. Use extra care to avoid the water stream if doing so.**
- Ensure that the cavitation nozzle is pointed away from the diver's or operator's hands, arms and body.
- Start the hydraulic power unit.
- Hold the lance tight and observe the calibration gauge (See Figure 5.1).
- Turn the knob on top of the pressure regulating valve until pressure reads 4,000-psi (275 bar) on the calibration gauge. Turning the knob clockwise will



increase the pressure and turning it counter clockwise will decrease the pressure.



**DO NOT ADJUST THE PRESSURE AT THE LANCE TO MORE THAN 4,000-PSI (275 BAR). HIGHER PRESSURE WILL NOT IMPROVE PERFORMANCE AND COULD RESULT IN SERIOUS DAMAGE TO THE PUMP.**



**HOSES ARE RATED FOR 4,000-PSI (275 BAR) PRESSURES ABOVE 4,000-PSI (275 BAR) COULD RESULT IN HOSE FAILURE.**

**This space intentionally left blank**

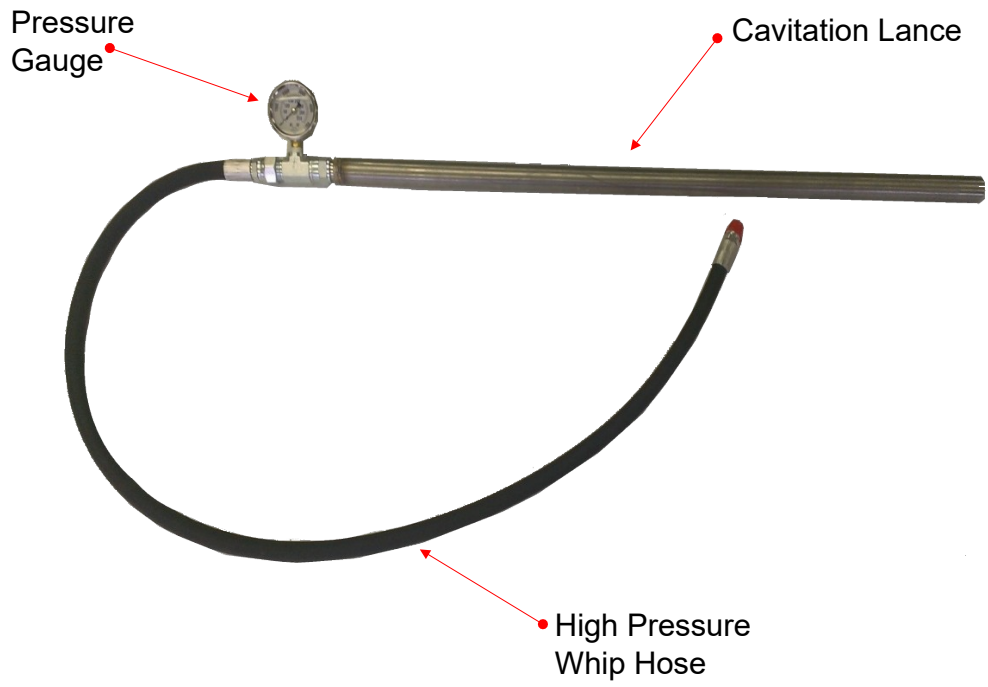

*Figure 5.1 – Lance Pressure Calibration*

## 5.5 Recommendations for Effective Results

When the ROV operator is ready to commence cleaning operations, verify that the lance is securely attached to the manipulator.

Once the hydraulic power unit is operational and the water jet stream is flowing from the lance, the ROV operator has to find the most effective distance between the lance nozzle and the surface being cleaned. (See Figure 5.2)

1. Engage the ROV's hydraulic power unit to activate the CaviBlaster unit.
2. The most efficient operating technique is to hold the nozzle 2-5 inches (5-12 cm) away from the surface to be cleaned and at a 25 to 45 degree angle to the surface being cleaned (See Figure 5.2). The ROV operator needs to observe the shape of the cavitating jet cone. At greater depths, the higher ambient pressure will cause the jet cone to be shorter. The widest zone of the cone is the most efficient part of the cavitating jet. Placing the nozzle closer than 2 inches (5 cm) from the surface being cleaned will not allow for efficient cavitation performance and will degrade the cleaning capability of the CaviBlaster system.
3. Follow all safety regulations that may be applicable to the work being performed.

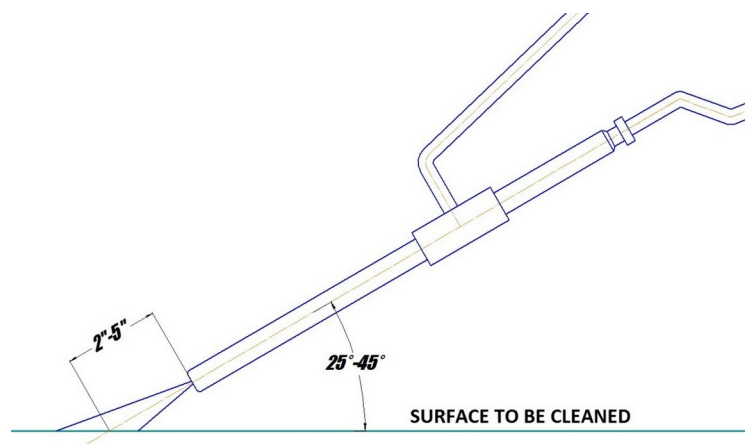

*Figure 5.2 – Lance Position for Best Cleaning Results*

## **5.6 Shutting Down the CaviBlaster 2040-ROV.**

1. Shut down the ROV hydraulic power unit, this will turn off the pressure pump and relieve pressure in the system.
2. It is now safe to remove the lance from the water.
3. Flush the system and rinse the power unit with fresh water at the end of the day or work shift.

**This space intentionally left blank**

**EOS**

## 6.0 MAINTENANCE

---

Maintenance on this unit should be restricted to authorized personal that have been properly trained. Review this manual, especially Section 3.0 *SAFETY INFORMATION*, prior to performing any service on this equipment.



Equipment must be **OFF** and pressure released from all hoses prior to performing any service work.



Only replace parts with those supplied or approved by CaviDyne. Use of any other parts may lead to equipment failure and severe personal injury.



CaviBlaster **MUST BE FLUSHED AND RINSED WITH FRESH WATER AFTER EACH USE IN SEA WATER.**



**FAILURE TO FLUSH AND RINSE THE UNIT WILL RESULT IN PREMATURE WEAR AND TEAR ON THE COMPONENTS AND DECREASED SERVICE LIFE.**



Failure to flush and rinse the unit can cause the pump valve(s) to stick in the open position. This will prevent the system from producing the correct operating pressure.

## 6.1 Basic Preventive Maintenance Recommendations

	After Every Use	Every 6 Months or 125 Hours*	Every 12 Months or 250 Hours*	Every 12 Months or 500 Hours*	Every 1,000 Hours
Ensure pump and oil pressure accumulator are filled with oil	X				
Check water inlet strainer cartridge(s) and clean if necessary	X				
Inspect hoses for wear or damage <sup>1</sup>	X				
Replace pump oil <sup>2</sup>				X	
Check pump valves and seals for wear & change if necessary					X

\* Whichever occurs first.

- 1) If any hose damage is found, replace hose immediately.
- 2) The initial oil change is required after 50 hours of operation. See pump manufacturer's literature in the Appendix for additional recommendations.

## 6.3 Pump Service

The high pressure water pump requires minimal maintenance. The pump oil should be checked on a regular basis. The pump crankcase should be COMPLETELY FILLED with SAE 30 viscosity non-detergent oil. See pump manufacturer's literature found in the *APPENDIX* for further information.

## 6.4 Inspection/Cleaning of Water Inlet Strainer

The water inlet strainer should be inspected and cleaned after each use of the CaviBlaster 2040-ROV.

## 7.0 TROUBLESHOOTING

---

### 1. WATER IN CRANK CASE

- Check the pump seals for damage
- Check the plungers for cracks
- Check the plunger rod O-ring for damage
- Check the oil pressure compensator bladder for damage

### 2. LANCE IS NOT CLEANING PROPERLY

- a. Remove the CaviBlaster unit from the water and mount the lance securely in a vice or test stand. Make sure the lance is pointed away from any personnel and any electrical systems or components in the area. The water jet from the lance can travel 30 to 40 feet (9 to 12 meters).
- b. Connect the hydraulic motor to a hydraulic power unit and start the hydraulic power unit. Verify that the hydraulic power unit is delivering the correct RPM (1160) and HP (55) required to operate the water pressure pump.
- c. If water is leaking out of the hose, fittings or connections replace the damaged component and securely tighten all connections.
- d. If water is leaking from the lance body contact CaviDyne for further instructions.
- e. Check lance and nozzle for foreign particles;
  - Visual inspection
  - Insert a small wire into nozzle orifices to check for obstruction(s) and “back-flush” with compressed air or pressurized water.

**(EOS)**

## 8.0 REPLACEMENT PARTS

---

<b>CaviBlaster 2040-ROV POWER UNIT REPLACEMENT PARTS</b>			
<b>RECOMMENDED ORDER QTY</b>	<b>QUANTITY PER ASSEMBLY</b>	<b>PART DESCRIPTION</b>	<b>PART NUMBER</b>
2	2	Water inlet strainer	CASS-20-1-100-316
1	1	Pump seal kit	31280
1	1	Pump valve kit	31292
1	1	Pressure regulator (optional)	CAT 7024.100
1	1	Regulating Unloader	UB 402
1	1	Safety relieve valve	CAT 9940
1	1	Oil pressure compensator	50MH52DBCSC

All parts can be  
ordered from:

### **CAVIDYNE, LLC**

5077 Fruitville Rd.; Ste 109-157  
Sarasota, FL 34235 USA

Phone: (352) 275-5319

Email: [support@cavidyne.com](mailto:support@cavidyne.com)  
[www.caviblaster.com](http://www.caviblaster.com)

**(EOS)**



## APPENDIX - COMPONENT LITERATURE

---

<p><b>Cross Hydraulic Gear Motor Model 50M052</b></p>	<p>Spec Sheet</p>
<p><b>CAT Pump Model 3560</b></p>	<p>Pump Spec Sheet Pump Exploded View Pump Dimensions Pump Service Guide Pump Torque Specs</p>
<p><b>CAT Pressure Regulator Model 7024.100</b></p>	<p>Valve Spec Sheet</p>
<p><b>Udor Model UB-402 Regulating Unloader Valve</b></p>	<p>Valve Spec Sheet</p>

<p>Cavidyne Cross CAT Udor USA</p>	
<p><b>Warranties</b></p>	

(EOS)